

Product Manual

8301

Numeric Keyboard / Display with Parallel TTL Interface

Quartech Corporation

15923 Angelo Drive
Macomb Township, Michigan 48042-4050

Phone: (586) 781-0373 FAX: (586) 781-0378
www.QuartechCorp.com

PM-8301 Revision 1

The product described in this document can have a variety of uses, the user and those responsible for applying this equipment must satisfy themselves as to the acceptability of each application and the use of the unit. Under no circumstances will QUARTECH CORPORATION be responsible or liable for any damage, including indirect or consequential losses resulting from the use, misuse, or application of the unit.

The text, illustrations, charts, and examples included in this document are intended solely to help explain applications of the product. Due to the many variables associated with specific uses or applications, QUARTECH CORPORATION cannot assume responsibility or liability for actual use based upon the data provided in this document.

No patent liability is assumed by QUARTECH CORPORATION with respect to the use of circuits, information, equipment, or software described in this document.

This document is subject to change without notice.

Table of Contents

Subject	Page
Section 1: Introduction	2
1.1 Manual Writing Conventions	2
Section 2: Electrical Connections	3
2.1 Data Inputs	5
2.2 Strobe Data In	5
2.3 Strobe In Select	5
2.4 Decimal Point Inputs	5
2.5 Negative Input	5
2.6 Electronic Lock	6
2.7 Interrupt	6
2.8 Strobe Data Out	6
2.9 Strobe Out Select	6
2.10 Data Outputs	7
2.11 Decimal Point Outputs	7
2.12 Negative Output	7
2.13 Reference	7
2.14 Data Valid	7
Section 3: DIP Switches	8
Section 4: Operation	9
4.1 Received Data Displayed Mode	9
4.2 Keyboard Data Mode	9
Section 5: Application Note	11
Appendices:	14
A: Error Codes	14
B: Electrical Characteristics	14
C: Installation Notes	15
D: Mounting Dimensions	16

The Model 8301 is an electronic, numeric entry and display panel, with a parallel TTL interface. It is designed to interface with any Programmable Logic Controller (PLC) that has TTL register I/O cards or 5 VDC I/O cards. A logical application is the replacement of thumbwheel switches and readouts to change timer and counter data within the PLC.

Data is sent to the 8301 through 16 TTL compatible inputs. The 8301 can interpret the inputs as a 16-bit binary number or as a 4-digit Binary Coded Decimal number (BCD). The 8301 can then display the data as a decimal number (from 0 to 65535) or a hexadecimal number (from 0 to FFFF).

The 8301 sends data to the PLC through 16 TTL compatible outputs. The data is entered through the keypad, either a decimal number or a hexadecimal number, and is sent to the outputs as either a 16-bit binary number or a 4-digit BCD number.

The 8301 is designed to be enclosure door mounted. The face of the unit is a laminated polyester back screened overlay including a five digit numeric display, three LED mode indicators, and sixteen tactile feel membrane switches. The switches and LED's are labeled to indicate their defined functions. A molded wrap around gasket seals the front and edges of the 8301 so when properly mounted will maintain NEMA 4/12 panel ratings. The rear of the 8301 is covered by a metal case so that no printed circuit boards are exposed. Four removable I/O terminal blocks, a two position removable power terminal block and three 8 position DIP switches are exposed through the back cover.

1.1 Manual Writing Conventions

The 8301 has a five digit display window, three discrete light emitting diodes (LED), an 8-position DIP switch, sixteen keys, and 54 discrete I/O terminals. Throughout this manual many references will be made to these entities, therefore, the following conventions have been established:

- ? Characters that would appear in the five digit display window will be shown in bold print and within quotation marks.

Example: **"-1234"** or **"-E0-"**

- ? Labels that refer to one of the three discrete LEDs will be shown in bold print and always in capital letters.

Example: **KEYBOARD DATA** or **KEYBOARD LOCKED**

- ? Key names will always be shown in bold print inside brackets.

Example: **[ENT/E]** or **[5]**

- ? Discrete Inputs or Outputs will always be shown in bold mixed case letters

Example: **Strobe Data In Low** or **Data Valid**

Section 2 Electrical Connections

The 8301 has four removable terminal blocks, grouped into two banks: bank 'A' and bank 'B'. In general, bank "A" terminals are input signals to the 8301 and bank "B" are output signal from the 8301. The drawing below shows the physical position of the terminals and indicates the assigned terminal numbers.

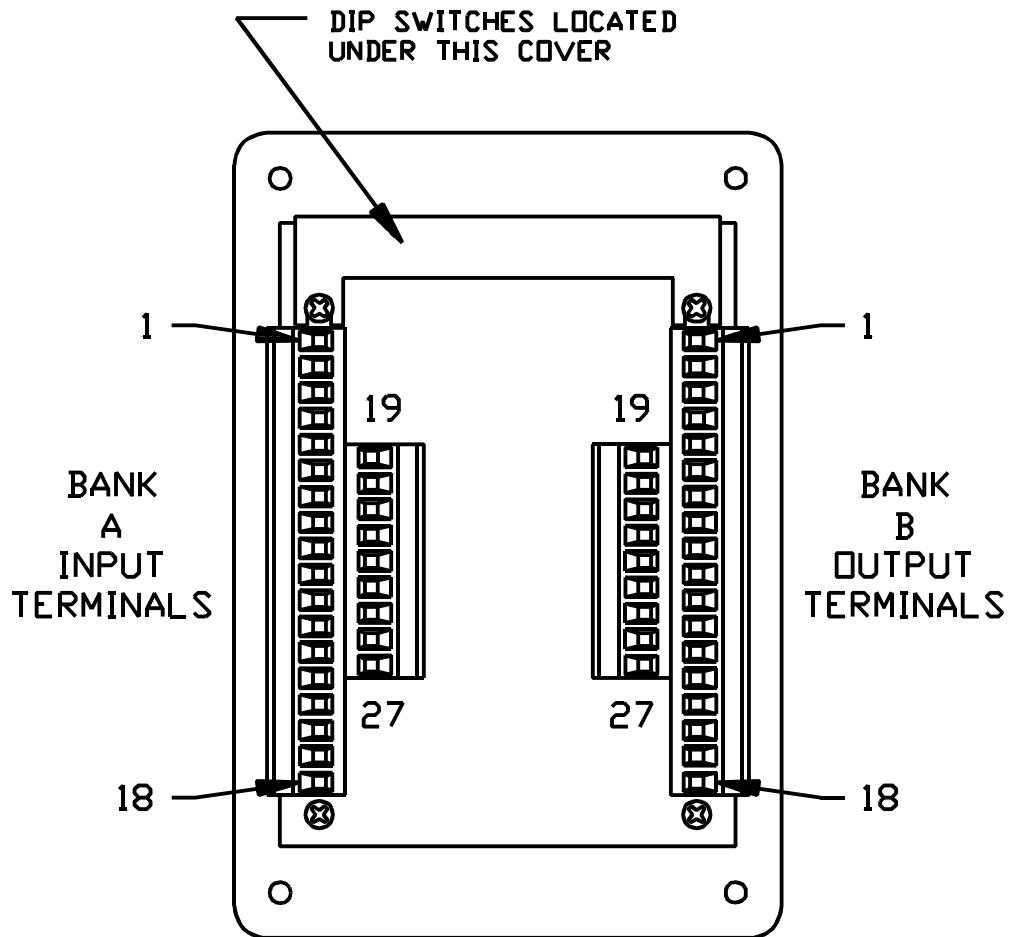

Section 2 Electrical Connections

The following table identifies each of the signals associated with the 8301. A detailed description of the signals is presented on the pages following this table.

Terminal Bank "A"				Terminal Bank "B"			
A1	Strobe Data In Low (input)			B1	Strobe Data Out Low (input)		
A2	Strobe Data In High (input)			B2	Strobe Data Out High (input)		
		Binary	BCD			Binary	BCD
A3	Data Input 1	1	1	B3	Data Output 1	1	1
A4	Data Input 2	2	2	B4	Data Output 2	2	2
A5	Data Input 3	4	4	B5	Data Output 3	4	4
A6	Data Input 4	8	8	B6	Data Output 4	8	8
A7	Data Input 5	16	10	B7	Data Output 5	16	10
A8	Data Input 6	32	20	B8	Data Output 6	32	20
A9	Data Input 7	64	40	B9	Data Output 7	64	40
A10	Data Input 8	128	80	B10	Data Output 8	128	80
A11	Data Input 9	256	100	B11	Data Output 9	256	100
A12	Data Input 10	512	200	B12	Data Output 10	512	200
A13	Data Input 11	1024	400	B13	Data Output 11	1024	400
A14	Data Input 12	2048	800	B14	Data Output 12	2048	800
A15	Data Input 13	4096	1000	B15	Data Output 13	4096	1000
A16	Data Input 14	8192	2000	B16	Data Output 14	8192	2000
A17	Data Input 15	16384	4000	B17	Data Output 15	16384	4000
A18	Data Input 16	32768	8000	B18	Data Output 16	32768	8000
A19	Decimal Point Input 1 (XXX.X)			B19	Decimal Point Output 1 (XXX.X)		
A20	Decimal Point Input 2 (XX.XX)			B20	Decimal Point Output 2 (XX.XX)		
A21	Decimal Point Input 3 (X.XXX)			B21	Decimal Point Output 3 (X.XXX)		
A22	Decimal Point Input 4 (.XXXX)			B22	Decimal Point Output 4 (.XXXX)		
A23	Negative Input			B23	Negative Output		
A24	Electronic Lock Input			B24	Reference Output		
A25	Interrupt Input			B25	Data Valid Output		
A26	DC Common (Power Supply Input)			B26	Strobe In Select (input)		
A27	+5.8 VDC (Power Supply Input)			B27	Strobe Out Select (input)		

2.1 Data Inputs (A3 through A18)

Sixteen **Data Inputs** are available for numeric data input. These inputs are TTL compatible and can be configured for high true logic or low true logic depending on the position of DIP switch A2. The 8301 can interpret the data as a 16-bit binary number or a 4-digit BCD number, depending on the position of DIP switch A3. The most significant bit is **Data Input 16**. **Data Input 1** is the least significant bit.

2.2 Strobe Data In (A1 & A2)

Each of the sixteen **Data Inputs** is feed through a "flow through" type latch. The **Strobe Data In** signals control the operation of the latches.

When the **Strobe Data In** input is held in its active state, the data at the **Data Inputs** flow through the latches. That is, a change of state at the input terminal will be recognized by the 8301. The instant the **Strobe Data In** signal is forced to its inactive state, the data at the **Data Inputs** is latched. Once the **Data Inputs** are latched, the signals at the input terminal can change without affecting the data stored in the 8301. The ability to latch the **Data Inputs** allows the input data bus to be shared with other devices (such as another 8301, or the 8301's output data bus).

Strobe Data In Low controls the least significant 8-bits of the data bus, **Data Input 1** through 8.

Strobe Data In High controls the most significant 8-bits of the data bus, **Data Input 9** through 16.

NOTE: For proper operation, the **Strobe Data In** inputs should be set to a valid TTL level. These inputs should never be left unterminated.

2.3 Strobe In Select (B26)

The **Strobe In Select** input will configure the **Strobe Data In** inputs to be active high or active low.

- ? If **Strobe In Select** = TTL high then **Strobe Data In** = active low.
- ? If **Strobe In Select** = TTL low then **Strobe Data In** = active high.

The **Strobe In Select** input has an internal pull up resistor which will hold it high if left unterminated.

2.4 Decimal Point Inputs (A19, A20, A21, & A22)

Four inputs are provided to control the four decimal points of the data display. The **Decimal Point** inputs use high true logic. When one of the **Decimal Point** inputs is set TTL high, its corresponding decimal point will light. The **Decimal Point** inputs are not latched. An internal pull-down resistor will hold the **Decimal Point** inputs TTL low (off) if they are left unterminated.

2.5 Negative Input (A23)

When the **Negative** Input is set TTL high, a negative sign will light. The negative sign is positioned in the left most digit of the 5 digit display. An internal pull-down resistor will hold the **Negative** Input TTL low if it is left unterminated. The **Negative** input is not latched.

2.6 Electronic Lock (A24)

When the **Electronic Lock** input is set TTL high, the 8301 keypad will "lock". That is, input data will be displayed in the data window but the keypad will be ignored. The **Electronic Lock** input must be held TTL low for normal keypad operation. An internal pull-down resistor will hold it TTL low (off) if it is left unterminated. The **Electronic Lock** input is not latched. This function will not interrupt the keypad operation, i.e., if an operator is in the process of making a keypad entry, the **Electronic Lock** function will not activate until the operation is completed.

2.7 Interrupt (A25)

The 5 digit display can display two different types of data: keyboard data and input (received) data. The **Interrupt** input allows an external device to force the 8301 to display the received data, found at the **Data Inputs**. The **Interrupt** input is active low. When the **Interrupt** input is set TTL low, the 8301 will switch into **RECEIVED DATA DISPLAYED** mode. That is, the 8301 will display the data currently flowing through or latched at its **Data Inputs**. As long as the **Interrupt** input is low, the 8301 will remain in **RECEIVED DATA DISPLAYED** mode, and the keypad will be held inactive. When the **Interrupt** input is returned TTL high, the 8301 will still remain in **RECEIVED DATA DISPLAYED** mode, however, the keypad will operate normal.

When the **Interrupt** input is low, whatever data is present at the 8301's inputs (16 **Data Inputs**, 4 **Decimal Point** inputs, and the **Negative** input) will be "echoed" at the corresponding outputs. This is intended as a test of the integrity of the 8301's I/O circuits.

2.8 Strobe Data Out (B1 & B2)

Each of the sixteen **Data Outputs** is feed through a "tri-state" driver. The **Strobe Data Out** signals control the operation of the drivers. When the **Strobe Data Out** input is held in its active state, the data in the 8301's output buffer is passed onto the **Data Outputs**. The instant the **Strobe Data Out** signal is set to its inactive state, the **Data Outputs** assume a high impedance state. The ability to "tri-state" the **Data Outputs** allows the output data bus to be shared with other devices (such as another 8301, or the 8301's input data bus).

- ? The **Strobe Data Out Low** input controls the least significant 8-bits of the data bus. **Data Output 1** through **Data Output 8**.
- ? The **Strobe Data Out High** input controls the most significant 8-bits of the data bus, **Data Output 9** through **Data Output 16**.

NOTE: For proper operation, the **Strobe Data Out** inputs should be set to a valid TTL level. These inputs should never be left unterminated.

2.9 Strobe Out Select (B27)

The **Strobe Out Select** input will configure the **Strobe Data Out** inputs to be active high or active low.

- ? If **Strobe Out Select** = TTL high then **Strobe Data Out** = active high.
- ? If **Strobe Out Select** = TTL low then **Strobe Data Out** = active low.

The **Strobe Out Select** input has an internal pull down resistor will hold it low if left unterminated.

2.10 Data Outputs (B3 through B18)

Sixteen **Data Outputs** are available for numeric data output, and can be configured as high true outputs or low true outputs depending on the position of DIP switch A2. The 8301 can encode the data as a 16-bit binary number or as a 4-digit BCD number, depending on the position of DIP Switch A3. The most significant bit is **Data Output 16**. The least significant bit is **Data Output 1**.

Each of the sixteen **Data Outputs** is feed through a "tri-state" driver. The **Strobe Data Out** inputs (described above) control the operation of the drivers.

2.11 Decimal Point Outputs

Four outputs are provided to indicate the position of the decimal point. A decimal point may be entered, using the **[.F]** key, at the time a numeric value is entered through the keypad. If a decimal point is entered, the appropriate **Decimal Point Output** will be driven high when the numeric value is passed through the **Data Outputs**.

The **Decimal Point Outputs** are high true and do not have "tri-state" capability.

2.12 Negative Output (B23)

A negative sign may be entered, using the **[-B]** key, at the time a numeric value is entered through the keypad. If a negative sign is entered, the **Negative Output** will be driven high when the numeric value is passed to the **Data Outputs**.

The **Negative Output** is high true and does not have "tri-state" capability.

2.13 Reference (B24)

The **Reference** output is controlled by the **[REF/A]** key on the 8301's keypad. If the **[REF/A]** key is pressed at the time a numeric value is entered through keypad, the **Reference** output will be driven high when the numeric data is passed to the **Data Outputs**. The **Reference** output is typically used to "mark" certain types of data so that the host device can discern between two different types of information. For example: address information and data information.

The **Reference** output is high true and does not have "tri-state" capability.

2.14 Data Valid (B25)

The **Data Valid** output is a "handshake" signal. It is driven TTL high, by the 8301, to indicate that data is present at the output buffer.

The **Data Valid** output does not have "tri-state" capability and is operated regardless of the state of the **Strobe Data Out** input.

Three 8-position DIP switches are accessible through the rear of the 8301 by removing a cover plate at the top rear of the unit. The cover plate is removed by first loosening the two phillips head screws which secure it then sliding the cover up and away from the unit. Only the middle 8-position DIP switch is used.

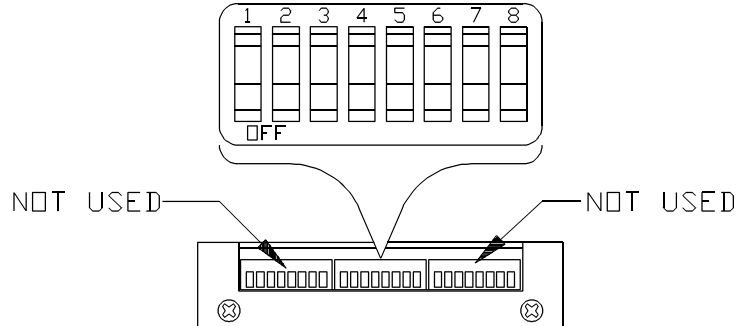

The following table defines the "ON" and "OFF" state for each DIP switch.

SWITCH	SETTING	FUNCTION
1	ON	Hexadecimal keypad entry.
	OFF	Decimal keypad entry.
2	ON	Data in/out low true.
	OFF	Data in/out high true.
3	ON	Data in/out in binary.
	OFF	Data in/out in BCD.
4	ON	Enable negative sign.
	OFF	Disable negative sign.
5	ON	Enable decimal point entry.
	OFF	Disable decimal point entry.
6	ON	Enable 'Received Data Display' mode.
	OFF	Disable 'Received Data Display' mode.
7	ON	Enable reference entry.
	OFF	Disable reference entry.
8	ON	Reserved for future use.
	OFF	Reserved for future use.

The five digit LED display on the 8301 is used for two different purposes, displaying data from the keyboard buffer or displaying data received from a host device. The [DIS/D] key allows an operator to toggle the display between the two display modes. The current display mode is indicated by the **KEYBOARD DATA** and **RECEIVED DATA DISPLAYED** LEDs.

4.1 Received Data Display Mode

Data present at the 8301 Data Input terminals is accepted at any time, regardless of the display mode; however, the 8301 will display data from the Data Input terminals, only if the display is in **RECEIVED DATA DISPLAYED** mode. There are two ways to force the 8301 into **RECEIVED DATA DISPLAYED** mode.

- ? An operator may use the [DIS/D] key to toggle between **KEYBOARD DATA** mode to **RECEIVED DATA DISPLAYED** mode.
- ? The host device may set the **Interrupt** input low. While the **Interrupt** input is low, the 8301 will remain in **RECEIVED DATA DISPLAYED** mode, and the [DIS/D] key will be ignored (this will essentially lock out the operator). Once the **Interrupt** input is returned high, the 8301 will still remain in **RECEIVED DATA DISPLAYED** mode, however, the function of the [DIS/D] key will be restored.

NOTE: The **RECEIVED DATA DISPLAYED** mode must be enabled by setting DIP switch A6 on. If the **RECEIVED DATA DISPLAYED** mode is not enabled, the 8301 will not enter this mode under any circumstances.

4.2 Keyboard Data Mode

Data is entered into the 8301 through the keypad. To enter data the unit must be in **KEYBOARD DATA** mode. On power-up, the 8301 will be in **KEYBOARD DATA** mode. The keys on the keypad will function as follows:

KEY		FUNCTION
[0] ? [9]	Numeric	Used to enter numeric data into the keyboard buffer.
[REF/A]	Reference/Hex	Used to control the Reference output.
[-/B]	Negative Sign/Hex	Used to display negative sign and to control the Negative Output.
[CLR/C]	Clear/Hex	Used to clear the keyboard buffer in preparation for a new entry, the Data Valid output will be driven low.
[DIS/D]	Display Toggle/Hex	Used to toggle between 'Keyboard Data' and 'Received Data Display' modes.
[ENT/E]	Enter/Hex	Used to terminate a keypad entry. When this key is pressed, the data is transferred from the keyboard buffer to the output buffer, and the Data Valid output is driven high.
[./F]	Decimal Point/Hex	Used to display a decimal point and to control the Decimal Point Outputs.

If Hexadecimal entry is selected (DIP switch 1) the letter keys, [A] through [F], will take precedence over the function of the keys. After all four digits of data have been entered, the key function will become active as defined above. This may force an operator to enter leading zeros to fill in an entry that otherwise wouldn't require four digits.

To send a new value to the output drivers the operator must key in the appropriate value including a decimal point, negative sign, or reference key; then press the [ENT/E] key. When the [ENT/E] key is pressed, the value displayed is transferred to the output drivers. Approximately 500ms latter the **Data Valid** output will be set high. The **Data Valid** output is intended to signal the host device that a new data entry has been made. The **Data Valid** output can be reset by the operator, by pressing the [CLR/C] key, or it can be reset by the host device, by forcing the **Interrupt** input low.

The following example will show how the 8301 can be used to view and change the contents of a Programmable Logic Controller's data registers. The PLC used in this example is an Allen-Bradley PLC-2/15, but the ideas presented may be applied to other PLC's.

The 8301 will be configured for BCD input and output. Since the PLC-2's data registers use three digit BCD, the 8301's most significant four **Data Outputs** will be left unused (See Figure 5.1). In this example, the 8301's most significant four inputs are cleverly used to signal an operator entry error.

The 8301 will display data received from the PLC, therefore DIP switch A6 must be "ON".

The 8301 will use its **Reference** output, therefore DIP switch A7 must be "ON".

MODEL 8301 INTERFACE TO AB 1771 SERIES I/O

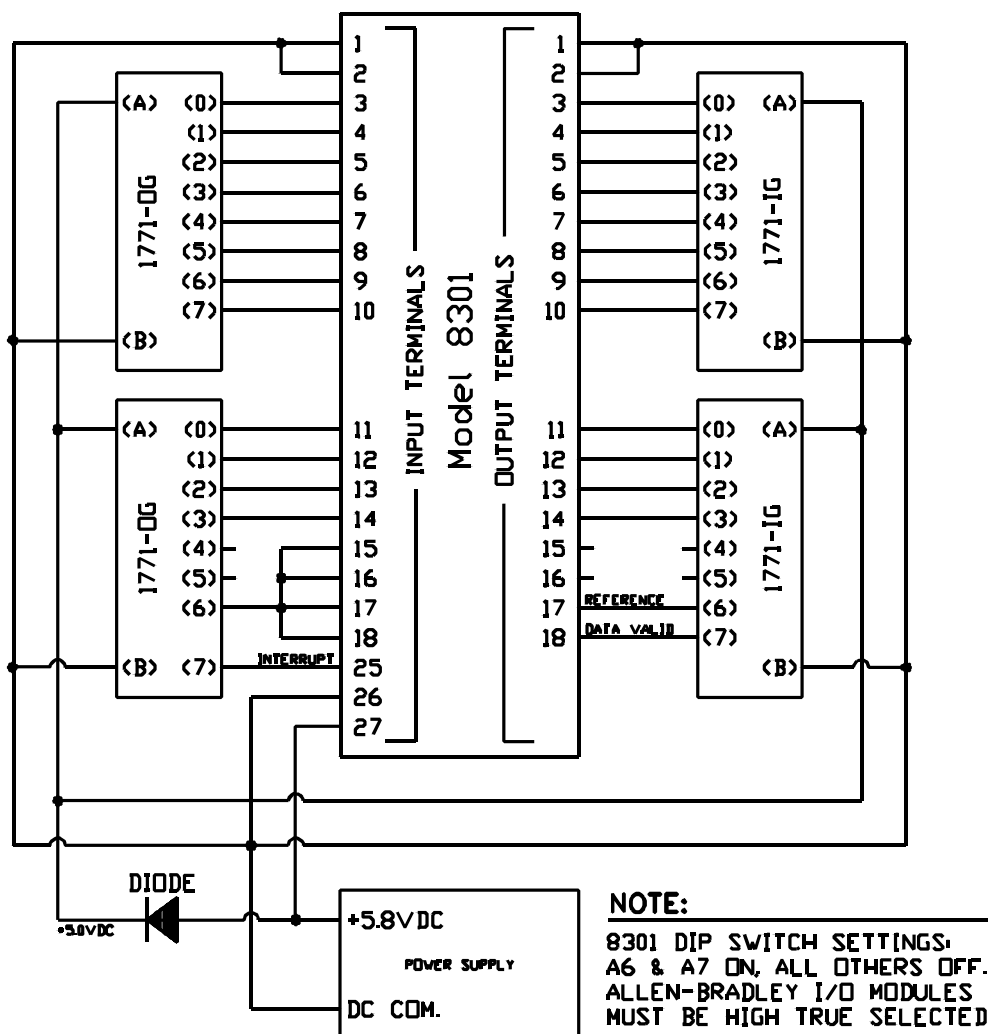

Figure 5.1

PLC-2 LADDER DIAGRAM TO INTERFACE QUARTECH 8301

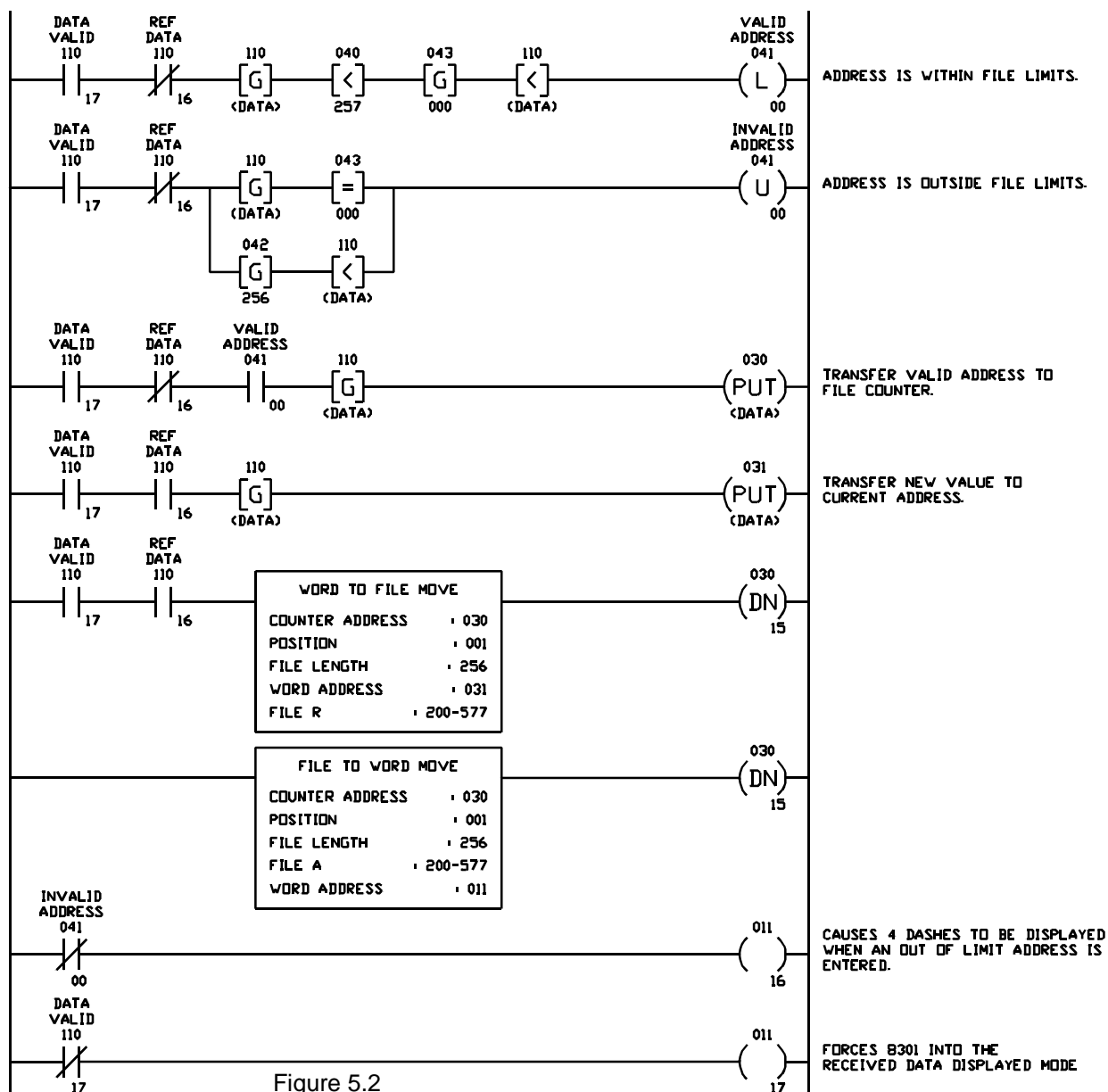

Figure 5.2

When examining the ladder logic diagram (Figure 5.2), keep in mind the following:

The **Data Valid** output will go high whenever a number is keyed in at the keypad and the [ENT/E] key is pressed. If the [REF/A] key is pressed before pressing the [ENT/E] key, the **Reference** output will also be driven high. This allows the PLC to distinguish between two types of information, in this case a register number or the register's data.

When the 8301's **Interrupt** input is forced low, the 8301 will switch to **RECEIVED DATA DISPLAYED** mode, and the **Data Valid** output will turn off.

The program on the previous page creates a table of data registers starting with word address 200 and ending at 577 (PLC-2 uses octal addressing). When the **Data Valid** line is high and **Reference** low, the 8301's output acts as an index or pointer into the table. When **Data Valid** and **Reference** are both high, the 8301's output is moved into the table, at the word address pointed to by the pointer.

- ? Rungs 1 and 2 test the data from the 8301 before using it as a pointer. The pointer must be a value from one to 256.
- ? Rung 3 moves the data from the PLC-2's input register to the address of the counter that controls the Word to File Move. This is the pointer into the table.
If **Data Valid** equals one and **Reference** equals zero, then the data is a pointer.
- ? Rung 4 moves a new value from the PLC-2's input register, to the file input address.
If **Data Valid** equals one and **Reference** equals one then the data is a register value.
- ? Rung 5 moves the new value from the file input address into the file location specified by the pointer.
- ? Rung 6 moves the value from the file location pointed to by the pointer to the PLC-2's output register and onto the 8301.
- ? Rung 7 signals an operator error if the pointer is outside the table. The error is actually caused by an illegal BCD number at the 8301's inputs. The illegal number is generated when **Data Inputs 13** through **16** are all tied together and controlled by 011/16.
- ? Rung 8 controls the 8301's **Interrupt** input, to force the 8301 into **RECEIVED DATA DISPLAYED** mode. When **Data Valid** is high, **Interrupt** will go low. When **Interrupt** goes low it sends the 8301 into **RECEIVED DATA DISPLAYED** mode, and clears **Data Valid**, which in turn sends **Interrupt** back high.

From the operator's point of view, the 8301 will function as follows:

The 8301 will have access to a table of data registers numbered from 1 to 256. To view the contents of one of the registers, the operator would key in the number of the data register, say 25, and press enter.

[2] [5] [ENT/E]

The 8301 will switch to **RECEIVED DATA DISPLAYED** mode and display the data currently in register number 25 (word address 231 in the PLC-2). To change the data from its current value to, lets say 368, the operator would switch back to **KEYBOARD DATA** mode, clear the keyboard buffer, key in the new value, press the [REF/A] key, then press enter.

[DIS/D] [CLR/C] [3] [6] [8] [REF/A] [ENT/E]

At this point, to view the contents of a different register, say number 75, the operator would switch back to "Keyboard Data" mode, clear the keyboard buffer, key in the new register number, and press enter.

[DIS/D] [CLR/C] [7] [5] [ENT/E]

Appendix A: Error Codes

On initial power up and during normal operation diagnostics are executed at key points. If an error occurs, the 8301 will display an error code indicating the type of failure or error. These include hardware failures, communication errors and operator entry errors.

ERROR	DESCRIPTION
-E1-	RAM Memory Error. ? Re-apply power. If error continues replace 8301.
-E2-	ROM Memory Error. ? Re-apply power. If error continues replace 8301.
ILL 1	Illegal BCD number on inputs. ? Data inputs have illegal BCD value.
ILL 2	Decimal number too large. ? Operator entered a decimal number greater then 65535.
ILL 3	Negative number out of range. ? Data inputs have negative number less then -9999.

Appendix B: Electrical Characteristics

CHARACTERISTIC	VALUE		
	MINIMUM	TYPICAL	MAXIMUM
Supply Voltage (A26, A27)	5.55 V	5.80 V	6.05 V
Supply current			750 mA
High-level input voltage	2.00 V	5.00 V	5.50 V
Low-level input voltage	-0.50 V	0.00 V	0.80 V
High-level output voltage	3.98 V	5.00 V	VCC
Low-level output voltage	0.00 V	0.00 V	0.39 V
Operating temperature range	0 °C	25 °C	60 °C
Relative humidity			95% non condensing

Appendix C: Installation Notes

Inspect the unit prior to installation for visible damage that may have occurred during shipment.

NOTICE

Any claim for damage should be filed with the carrier or his agent.
Also notify your distributor so that corrective action can be taken.

MOUNTING:

The 8301 is designed to be mounted in the panel door or on an operators console for ease of use. The attached template may be used to assist in the drilling and cutting of the mounting holes for the unit.

Care should be taken to protect the unit from metal chips and conductive particles. Failure to protect the unit may cause failure when power is applied and may void the warranty.

A minimum clearance of six inches should be kept between the unit and any other device that generates heat. In the event that the internal enclosure temperatures periodically exceeds 60 Deg. C (140 Deg. F), fans or a purge air system should be used to increase the air flow and eliminate "Hot Spots" that occur within the panel. Under extreme conditions, air conditioning of the panel maybe required.

ELECTRICAL:

The 8301 is designed and constructed to minimize the effects of harsh industrial environments. However, when any control system operates under extreme conditions, additional measures must be taken. Additional steps may be required to suppress major sources of interference, should interference become a problem. Obvious sources are inductive items such as relays, motor starters, solenoids and "hard contacts". If suppression is used, suppressor should be placed as close to the item as possible for maximum effectiveness.

CAUTION

The power to the 8301 must be turned off while changing any of the DIP switches or working on any electrical termination; to protect the operator, equipment and unit from possible harm.

Appendix D: Mounting Dimensions

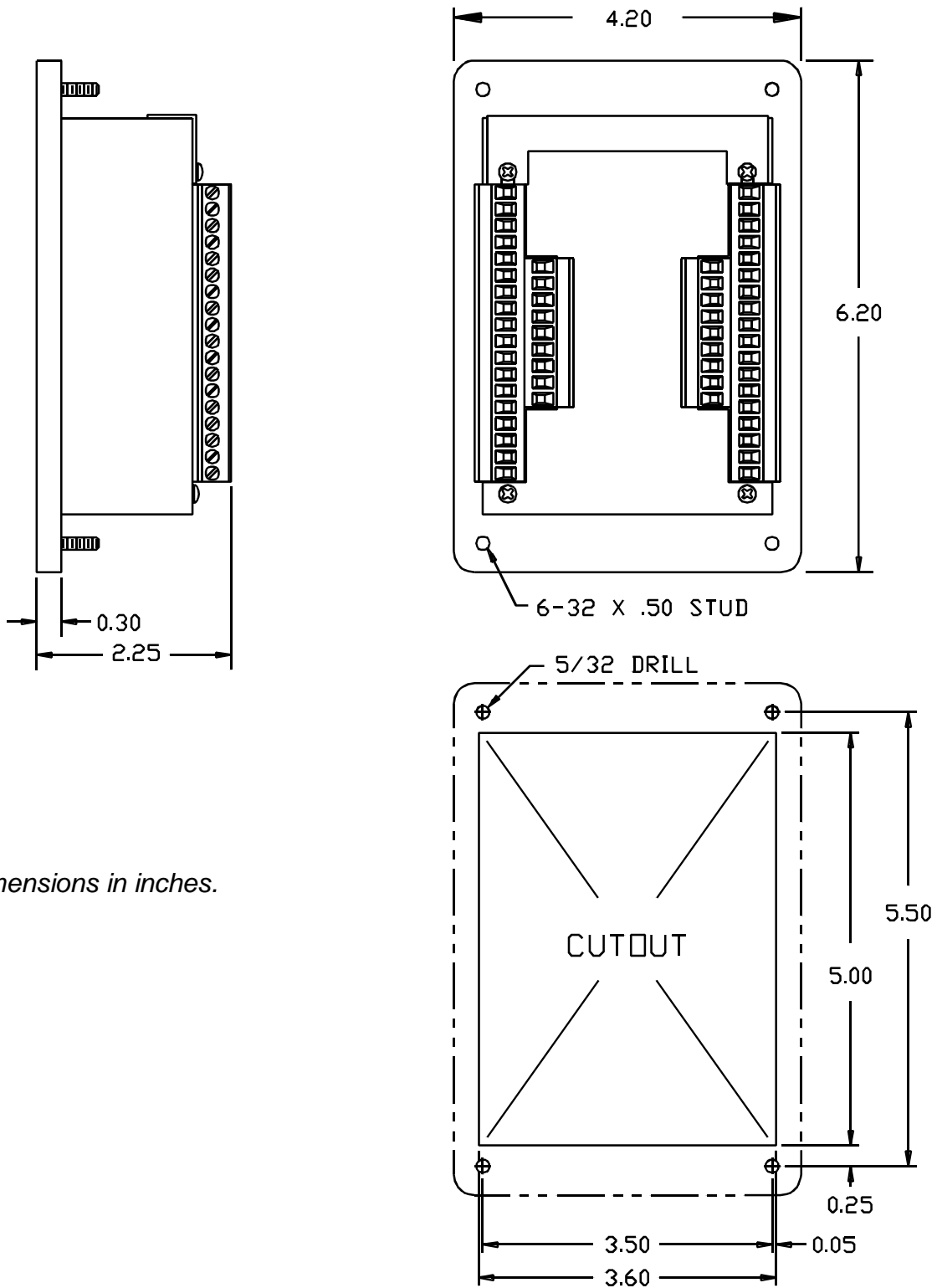

All dimensions in inches.