

Product Manual

8330GMX

Register Access Panel with Modbus Interface

Quartech Corporation

15923 Angelo Drive
Macomb Township, Michigan 48042-4050

Phone: (586) 781-0373 FAX: (586) 781-0378
Email: Sales@QuartechCorp.com

PM8330GMX Revision 4

The product described in this document can have a variety of uses, the user and those responsible for applying this equipment must satisfy themselves as to the acceptability of each application and the use of the unit. Under no circumstances will QUARTECH CORPORATION be responsible or liable for any damage, including indirect or consequential losses resulting from the use, misuse, or application of the unit.

The text, illustrations, charts, and examples included in this document are intended solely to help explain applications of the product. Due to the many variables associated with specific uses or applications, QUARTECH CORPORATION cannot assume responsibility or liability for actual use based upon the data provided in this document.

No patent liability is assumed by QUARTECH CORPORATION with respect to the use of circuits, information, equipment, or software described in this document.

This document is subject to change without notice.

Table Of Contents

Section 1: Introduction	1
Key Definitions	1
Mode Indicators	2
Station Number Selection	3
Access Limits	3
Section 2: Open Mode Operation	4
Section 3: Enhanced Mode Operation	6
Reserved Register Block	6
Last Register Entered	9
Read & Write Access Limits	9
Write Data Limits	9
Security Locks	10
Decimal Points	11
Forced Register Display	12
Five Digit Forced Entry	12
Display Segment Control	13
PLC Initiated Error Display	14
Offset Addressing	14
Appendix A: DIP Switch Assignments	15
Appendix B: Operating Fault Indicators	16
Appendix C: Communication Cables	17
Appendix D: Specifications	18
Appendix E: Installation	19
Appendix F: Reserved Register Block Work Sheets	20

The 8330GMX is a Register Access Panel specifically designed for use with the Modicon Modbus family of Programmable Controllers. The 8330GMX communicates as an RS-232-C Modbus master allowing it to interface directly with the 584, 884 and 984 controllers. Communicating with the PLC through the programming port eliminates the need for input/output modules and additionally eliminates the need for ladder logic programming.

Operating in the "Open Mode" the 8330GMX can view and modify all of the 40000 series data registers. Operating in the "Enhanced Mode" allows the system programmer to restrict the 8330GMX to view and/or modify a specific block of registers and also limit the write value. The addition of security locks, display segment control and program initiated error code display makes the 8330GMX the perfect choice for many control applications.

Fast Start

Every effort has been made to make the 8330 a simple product to apply and operate. Sometimes the best way to learn the operation of a new product is to hook it up and try it out. If this is your philosophy, then here's what to do.

1. Plug the communications cable between the 8330GMX and the PLC.
2. Set all DIP switches on the 8330 to the off position.
3. Apply power to the programmable controller.
4. Connect the 8552 Power Supply (5 VDC at ½ AMP) or equivalent to the 8330GMX.
5. Apply power to the Power Supply.

Important! Check the voltage at the terminals located on the 8330GMX and adjust to 5.1 VDC.

6. Proceed to the section titled Open Mode Operation (page 4).

Key Definitions



Assuming the CLOC function is selected - If unit is currently unlocked pressing the "LOCK" key will immediately lock the keypad and "CLOC" will be displayed. If the unit is currently locked the "LOCK" key must be pressed after all digits of the combination are entered to unlock the keypad.



Pressing this key will temporarily toggle the unit from register data mode to register number mode or vice versa until the key is released.

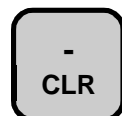

Negative key - does not function on this unit.
CLR -Clears the display and key entry buffer which allows a new register number or new register data to be entered.

NEW REG

Operates as the register number enter key. If the unit is in the "REGISTER DATA" mode, pressing this key will toggle the unit to the "REGISTER NUMBER" mode.

This key will function in two different ways depending upon the setting of DIP Switch A6 (Auto Increment/Reduced Keystrokes).

When DIP Switch A6 is ON, the NEW REG key will function in an Auto Increment Mode. Let us assume that a register number has been entered, the contents of that register is being displayed and the "REGISTER DATA" LED is on; pressing the NEW REG key will toggle the display showing the register number currently being accessed. Two options are now available to the operator:

1. Pressing the NEW REG key a second time will increment the register number by one.
2. Pressing the CLR key will clear the display, the 8330 is now ready for a new register number to be entered.

When DIP Switch A6 is off, the NEW REG key will function in an ENTRY READY Mode. Let us assume that a register number has been entered, the contents of that register is being displayed and the "REGISTER DATA" LED is on; pressing the NEW REG key will toggle the display back to the "REGISTER NUMBER" mode and clear the display. The 8330 is now ready for a new register number to be entered.

NEW DATA

Operates as the "REGISTER DATA" enter key. If the unit is in the "REGISTER NUMBER" mode, then pressing this key will toggle the unit to the "REGISTER DATA" mode.

LAST ENT

Pressing this key allows the operator to view the last data sent to the controller or the last register number entered depending upon the mode the unit is in. Releasing the key returns the unit to its previous condition.

Mode Indicators

Three LEDs are located just below the display window and indicate the current 8330 operating mode and status.

- | | |
|----------------------------|---|
| Register Number LED | Indicates the value on the display is a register number. If an error code is being displayed, it is register number related. |
| Register Data LED | Indicates the value on the display is a data value. If an error code is being displayed, it is data related. |
| Keyboard Locked LED | Indicates the keypad is inactive unless "CLOC" is being displayed. During that time only a formatted entry relative to the combination entry is accepted. |

Station Number Selection

DIP switches B2, B3, B4 and B5 select the station address. The station address must be set the same as that of the programmable controller. If the station addresses are not the same, an error - E5 - (No Response From PC) will occur. For most applications the DIP switches will be set for station one since this is the initial default of the controllers. Larger station numbers would generally be required when the 8330 is connected to a 584 or 984 that may also be part of a Modbus network.

Station Address

DIP B2 = Binary 8 DIP B3 = Binary 4 DIP B4 = Binary 2 DIP B5 = Binary 1

Access Limits

On initial Power Up the 8330 sends an identification request command to the controller. Once identified default read, write and data limits are set based on the type of controller. The following table shows the default settings.

PLC Default Settings

PLC Type	Low Read	High Read	Low Write	High Write	High Data
Micro 84	1	32	1	32	999
484	1	254	1	254	999
584	1	9999	1	9999	DIP A5 Off - 9999 DIP A5 On - 65535
884	1	864	1	864	
984	1	9999	1	9999	

The 8330 next checks for enhanced mode. If selected, dip switch A1, A2, and A3 will be checked. If any of these DIP switches are set the 8330 will read the appropriate limit value from the Reserved Register Block Table and store it at the associated limit location in the 8330.

During operation if a register number is above or below the set limit is entered, the 8330 will display -HI- or -LO- respective to the limits set. Pressing the "CLR" key will set the unit to the Register Number Ready Key.

When register data is being changed, limit errors can be caused in two ways. First if the data value is above the set limit, the 8330 will display -HI-. If the "CLR" key is pressed the unit will go to the REGISTER DATA ready mode and a new value may be entered. Second if the current register accessed is not within the write limits the 8330 will display -HI- or -LO- respective to the limits set, turn off the "REGISTER DATA" LED and turn on the "REGISTER NUMBER" LED. Pressing the "CLR" key will set the unit to the REGISTER NUMBER ready mode.

Because the enhanced mode limits override the Power Up default limits it is possible to enter a register number that is higher then the controller supports but lower then the Hi Read and/or Write limits.





If this should occur the controller will respond with the exception code 2 (Illegal Date Address). The 8330 will compare the register number entered to the Hi Read and Write limits. If the limit value is higher than the register number entered the limit will be reset to the value of the register number entered minus one. The 8330 will then display -HI-, set the "REGISTER NUMBER" LED to on if not already on and turn the "REGISTER DATA" LED off if not already off. Pressing the "CLR" key will set the unit to the REGISTER NUMBER ready mode. If the same number were entered again the 8330 would immediately respond with a -Hi- error, no transmission would occur.

Section 2: Open Mode Operation



In its default mode of operation, referred to as OPEN MODE (dip switches B5 - C8 OFF), the 8330 can view and modify any of the 40000 series registers. On Initial Power Up, the 8330 will display 3-X-X. The 3 indicates a MODBUS series compatible executive. The next two digits indicate the version level. During this display, default parameters are set and diagnostics are performed. If successful, the display will blank except for a cursor in the right most character position. The REGISTER NUMBER LED will be ON. This will further be referred to as the Register Number Ready mode. The operator may now enter a register number.

When entering the desired register number, the operator does not enter the 40000 prefix. For example, if the operator wishes to view register 40125; the operator enters the number 125.

Once the desired register has been entered, the operator must press the NEW REG key. The REGISTER NUMBER LED will turn off, the REGISTER DATA LED will turn on and the display will show the numeric content of the register entered. The register is continually read offering real time display. At this point four keys are active on the keyboard, LAST ENT, VIEW, CLR and NEW REG. They function as follows:

-  When pressed, the display will show the last data value entered by the operator. If no value has been entered by the operator, the display will show "0". The display will continue as long as the key is held down.
-  When pressed, the REGISTER DATA LED will turn off, the REGISTER NUMBER LED will turn on and the display will show the register number currently accessed. When the key is released, the 8330 will return to the register data display mode.
-  When pressed, the display will blank except for a cursor in the right most digit position. This is referred to as the register data ready mode. The operator may key in a new value. Once the new value has been keyed in, the operator may press NEW DATA to send the new value to the PLC.
-  How the 8330s responds to this key is dependant on the setting of switch A6. Assume A6 is off: when pressed, the 8330 will go to the register number ready mode with a cursor in the units position. If on, the NEW REG key will function in an auto increment mode.

Assuming the operator presses the NEW REG key with all DIP switches off, the 8330 will go to the register number ready mode. The operator may key in a new register number, then press NEW REG to view its contents or press one of three active function keys LAST ENT, VIEW or NEW DATA. The 8330 response to the three function keys as follows:

-  When pressed, the display will show the last register number that was entered by the operator (at this point it is still the current register being accessed). When released, the 8330 will return to the Register Number Ready mode.
-  When pressed, the REGISTER NUMBER LED will turn off and the REGISTER DATA LED will turn on. The display will show the contents of the currently accessed register. When released, the 8330 will return to the register number ready mode.
-  When pressed, the REGISTER NUMBER LED will turn off and the REGISTER DATA LED will turn on. The display will show the contents of the currently accessed register.

Section 2: Open Mode Operation

The LAST ENT and VIEW keys are always active in open mode. These keys are both momentary and when pressed simply point the display to various display buffers and have no affect on the data. Pressing either of these keys during the middle of data entry will not affect the current data in any way.

The CLR key is always active in open mode. Pressing the CLR key simply clears the 8330 key entry buffer, it does not change any data. If the CLR key is pressed accidentally, recovery requires pressing either the NEW REG or NEW DATA key (opposite key to mode 8330 is then in).

NOTE: The LOCK key is never active in open mode.

Example: Assume that you want to change the data value of register 137 from 0 to 488.

1. With the 8330 in the register number mode (REGISTER NUMBER LED on and a cursor is the least significant digit position), press the keys 1, 3 & 7 in order. The display will show each number as it is entered with the cursor preceding the desired register number.
2. Press the NEW REG key. The REGISTER NUMBER LED will go off and the REGISTER DATA LED will now lite. The display will show the value 0.
3. Press the CLR key, the 0 will be replaced by a cursor, and press the 4, 8 & 8 keys in order. The display will reflect the entry of each of these keys in the order entered with a cursor in the most significant position.
4. After all of the digits have been entered, press the NEW DATA key to enter the data. The cursor will disappear indicating the data has been changed.
5. To select an new register to display, press the NEW REG key.

Section 3: Enhanced Mode Operation

When operated in the open mode, the 8330 affects only the current register accessed and only if a new data entry is made. The enhanced mode offers the functions available in open mode plus additional functions including Combination Lock, Soft Lock, User Defined Read/Write/Data Limits, PLC initiated Error Displays, Display Segment Control, and Decimal Point.

The enhanced mode is enabled by setting dip switches B6 - C8 to a legal or valid address. This automatically enables the Command Register Block locations. During enhanced mode operation, data will be exchanged between the 8330 and PLC through the command register and reserved register block. Much of this exchange is controlled by ladder logic programs within the PLC written to take advantage of specific 8330 functions. Description and application hints on the various enhanced mode functions can be found in sections specifically covering each function.

Reserved Register Block

When operated in the Enhanced mode a block of registers must be reserved for an exchange of data between the 8330 and the PLC. The number of reserved registers is dependent on the Enhance Mode functions selected which include limits, combination lock and direct segment control. The minimum number of registers reserved is two and are labeled "Command Register" and "Number Of Last Register Entered".

The Reserved Register Block (RRB) exists when a valid register number is set on Dip switches B6 through C8.

The address of the first register (command Register) in the RRB is selected as a four digit value.
Note the 40,000 prefix is not used.

DIP Switch	Binary Value	DIP Switch	Binary Value
B6	1024	C4	16
B7	512	C5	8
B8	256	C6	4
C1	128	C7	2
C2	64	C8	1
C3	32		

Example: To assign the Command Register as register 40500, set dip switches B6 through C8 as follows:

DIP Switch	Binary Value	DIP Switch	Binary Value
B6	OFF	C4	OFF
B7	OFF	C5	OFF
B8	OFF	C6	ON
C1	OFF	C7	OFF
C2	ON	C8	OFF
C3	ON		

Section 3: Enhanced Mode Operation

The Reserved Register Block is read by the 8330 during power up based on various switch settings. The values read will be retained by the 8330 as long as power is applied. If a change is made in the RRB, the 8330 can be forced to reread the RRB by two different methods.

1. Power the 8330 down then power back up.
2. Latch Bit 16 in the Command Register. The 8330 will unlatch the Bit when the update is completed. If Bit 16 is forced ON continuously, the 8330 will continually update the RRB. This will greatly slow the response of the 8330.

The following circuit is recommended:

Assume Command Register is 40100

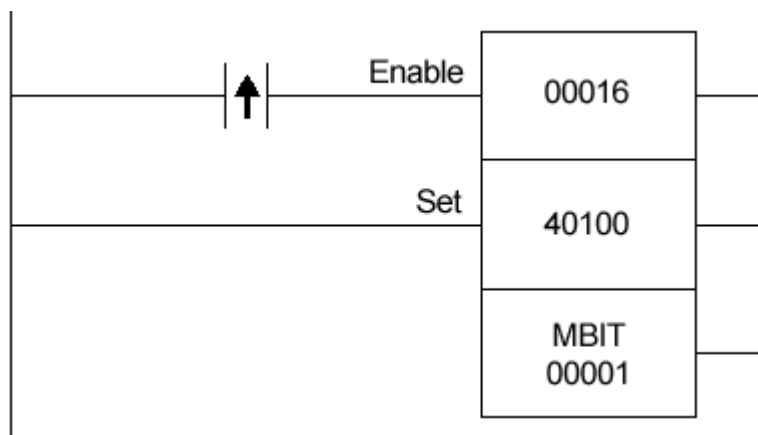

Single Bits in the Command Register are monitored and/or modified by the 8330. This allows the PLC to force the 8330 into various modes and also allows the 8330 to offer status information to the PLC.

RESERVED REGISTER BLOCK

Address	Assignment	
4XXXX (RRB)	Bit 16	Update limits Set by the PLC after a limit or combination change is made. Not required if 8330 is powered off then on. Reset by 8330 after limits are read.
	Bit 15	Keypad soft lock Set by the PLC to disable 8330 keys. Reset by the PLC to enable 8330 keys.
	Bit 14	Data change made Set/reset by 8330 to indicate a register was modified.
	Bit 13	Display segment control Set by the PLC to enter D.S.C. mode. Reset by the PLC to exit D.S.C. mode.
	Bit 12	Force display to ERR1
	Bit 11	Force display to ERR2 Set by the PLC to activate the display. Reset by 8330 as an acknowledgment.
	Bit 10	Force display to ERR3
Bit 9	Forced Register Display Set/reset by the PLC.	

RESERVED REGISTER BLOCK Continued

Address	Assignment
4XXXX (RRB)	Bit 8 Invalid combination Set by 8330 when operator keys in the wrong combination. Reset by 8330 when CLR key is pressed.
	Bit 7 Keypad combination lock Set by 8330 whenever unit is in CLOC. Reset by 8330 when valid combination is entered.
	Bit 6 Decimal point 2
	Bit 5 Decimal point 3
	Bit 4 Decimal point 4 Bits 6 through 3 are set/reset by PLC.
	Bit 3 Decimal point 5
	Bit 2 Force Five Digit Entry Set/reset by PLC.
	Bit 1 Spare
4XXXX + 1	Number of last register entered. Written by 8330 each time a new register is entered. Allows PC to know what 8330 is viewing. May be used to activate message displays.
4XXXX + 2	Low Data Limit.
4XXXX + 3	High Write Limit.
4XXXX + 4	Low Write Limit
4XXXX + 5	High Read Limit
4XXXX + 6	Low Read Limit
4XXXX + 7	High Data Limit
4XXXX + 8	Combination lock value.
4XXXX + 9	Direct Segment Control Character 1.
4xxxx + 10	Direct Segment Control Character 2
4xxxx + 11	Direct Segment Control Character 3
4xxxx + 12	Direct Segment Control Character 4
4xxxx + 13	Direct Segment Control Character 5

When the Reserved Register block is formed, register numbers are allotted for all functions. If a particular function is not being used, i.e. display segment control, those register numbers assigned to that function may be used by the PLC for other purposes. A work sheet is provided in Appendix F. Using it along with the check list will step you through the implementation of these functions.

- When the enhanced mode is selected, two tests are performed by the 8330 on power up. First, the word address set on DIP switches B5 through C8 is compared to the default low read limit calculated by the 8330. If the DIP switch value is less than the low default value, the 8330 will display error "-Eb-".
- If the first test is passed, the 8330 will add the number of words required by the Reserved Register Block to the DIP switch value. This new value is compared to the default high read limit. If the new number is greater than the high default value, the 8330 will display error "-EC-".

Last Register Entered

If the 8330 is operated in the enhanced mode, the second location in the Reserved Register Block is automatically enabled. When a Register Address is accepted by the 8330, that register number is put into the second Reserved Register Block location. This feature allows the PLC to know what register the 8330 is currently viewing. This allows a method of synchronizing interaction between the 8330, PLC and other peripheral devices.

When a new value for the currently accessed register is accepted, the 8330 will pulse bit 14 in the command register. This feature allows the PLC to know when data is written to a register and what the address is of that register.

Example: If address 40100 is being viewed by the 8330, then Reserved Register Block location X+001 would hold 100. The 40,000 prefix is not included.

Note: These features are not enabled when the 8330 is operated in the open mode.

Read & Write Access Limits

When the 8330 Enhanced Mode is selected, the system designer may reassign the High/Low access limits providing they remain within the default boundaries. In addition, Read Access may be authorized while restricting Write Access.

Six registers are available in the Reserved Register Block for reassigning limit values. A few ground rules and options must be considered when limits are reassigned.

- Write limits must fall within the boundaries of the read limits to be functional. A register can not be changed if it can not be first read. The exception is Forced register Display Mode.
- A valid Command Register must be set on dip switches B6 through C8.
- Dip switch A1 and/or A2 must be on to enable the desired limit to be acquired from the Reserved Register block. If write limits are to be the same as the Read Limits then dip switch A1 may be left off and only Read Limits need be set ON.

Write Data Limits

A two registers are available in the Reserved Register Block to store the High and Low Write Data Limit. When Write Data Limits are not selected the 8330 sets default values based on the Access limits received from the PLC on power up.

In the larger PLC's, 584/884/984, Dip Switch A5 can effect the default High Data Limit. When A5 is ON, the default limit is 65535.

If the operator enters a Write Value into the 8330 that is outside the Write Data Limit boundary, the Register Data Led will light and the display will show "-HI-" or "-LO-". Pressing the "CLR" key will allow the operator to key in a new value.

To set User Write Data Limits, the following three items must be considered:

- Switches B6 - C8 must be set to a legal or valid address.
- Switch A3 must be set on enabling the desired limits to be acquired from the Reserved Register Block.
- Valid values (0 - 65535) must be stored in the Reserved Register Block.

Four or Five digit Entry/Display is allowed by the 8330. The number of digits allowed is set by switch A5.

Switch A5 ON = Five digit entry & display
Switch A5 OFF = Four digit entry & display

When switch A5 is ON, 5 digit data is accepted and displayed by the 8330. The maximum value that can be entered will be 65535. However, this may be restricted by the High Write Data Limit. The maximum value that can be displayed is 65535 decimal.

When switch A5 is OFF, 4 digit data is accepted and displayed by the 8330. The maximum value that can be entered will be 9999. However, this may be restricted by the High Write Data Limit. The maximum value that can be displayed is 9999 decimal.

Security Locks

Two methods of locking the 8330 are available: soft lock and/or combination lock. Either or both methods may be used as the application requires. Security locks are part of the enhanced mode functions and so require DIP switches B6 - C8 set to a valid register number.

SOFT LOCK:

When bit 15 in the Command Register is set the 8330 keypad will become inactive immediately. The 8330 will remain in its current mode unless changed by the processor. When bit 15 is reset, the keypad will become active and normal operations will resume. This lock is called SOFT LOCK because it is controlled by program software, however, when applications require a key switch, a simple solution is to bring the key switch into the PLC via an input module and use the contact from that input to control bit 15 in the Command Register. The following circuit is recommended:

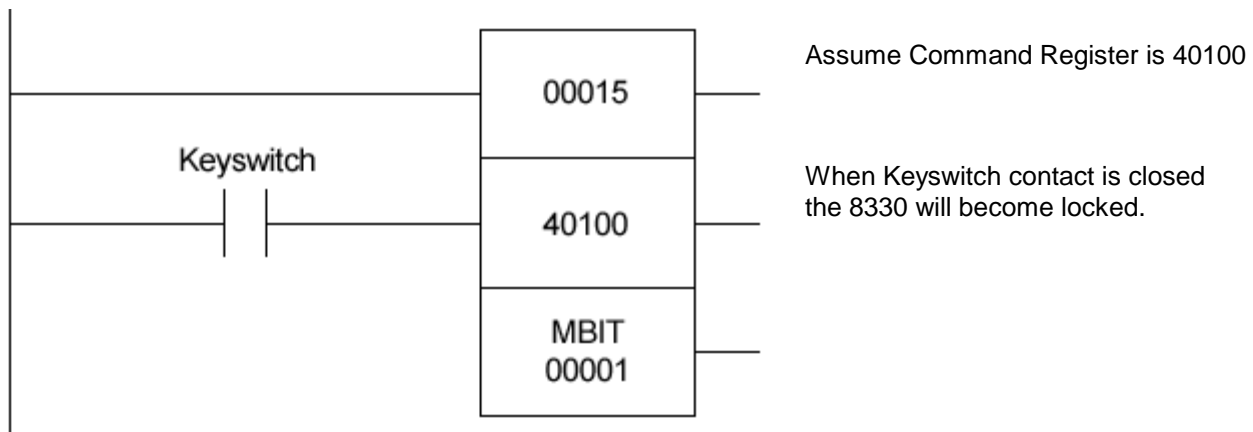

Combination Lock:

During Power-Up, the 8330 will test for CLOC. Enabling the combination lock additionally requires setting dip switch A4 ON and storing a combination value in the Reserved Register Block. If the CLOC mode is correctly enabled, the 8330 will display "CLOC", set the "KEYBOARD LOCKED LED" ON, set bit 7 in the Command Register then wait for a combination entry. The combination must be entered including leading zeros until all five digits are entered.

The digits are not displayed as they are entered. Next press the LOCK key. If the combination is incorrect, the 8330 will set bit 8 in the Command Register and begin flashing CLOC on the display. Pressing the CLR key will stop the flashing, clear bit 8 and allow a new value to be entered. The combination may be changed at any time by moving a new value into the Reserved Register Block then setting bit 16 in the Command Register. This is useful in applications that may require a new combination for each works shift. It is also possible to SOFT LOCK the 8330 after a particular number of incorrect combination entries by using a counter incremented by bit 8 of the Command Register and setting bit 15 in the Command Register when the preset is reached.

This example will soft lock the 8330 after five consecutive incorrect combination lock entries. The Command Register is at 40100.

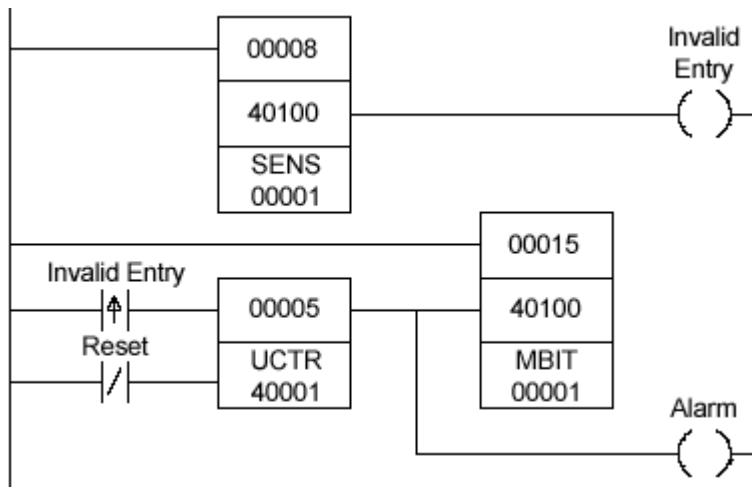

Decimal Points

In many cases it is advantageous to display a value to the operator with a decimal point. This is accomplished by setting one or more bits in the Command Register to achieve the desired display.

Command Register Bit Number	Function
6	Decimal Point Between Digit 1 & 2
5	Decimal Point Between Digit 2 & 3
4	Decimal Point Between Digit 3 & 4
3	Decimal Point Between Digit 4 & 5

Section 3: Enhanced Mode Operation

In the following example, let's assume a tenth of a second timer has been programmed with preset in 40001 and accumulator in 40002. The Command Register is 40100 and that the Last Register entered is therefore 40101.

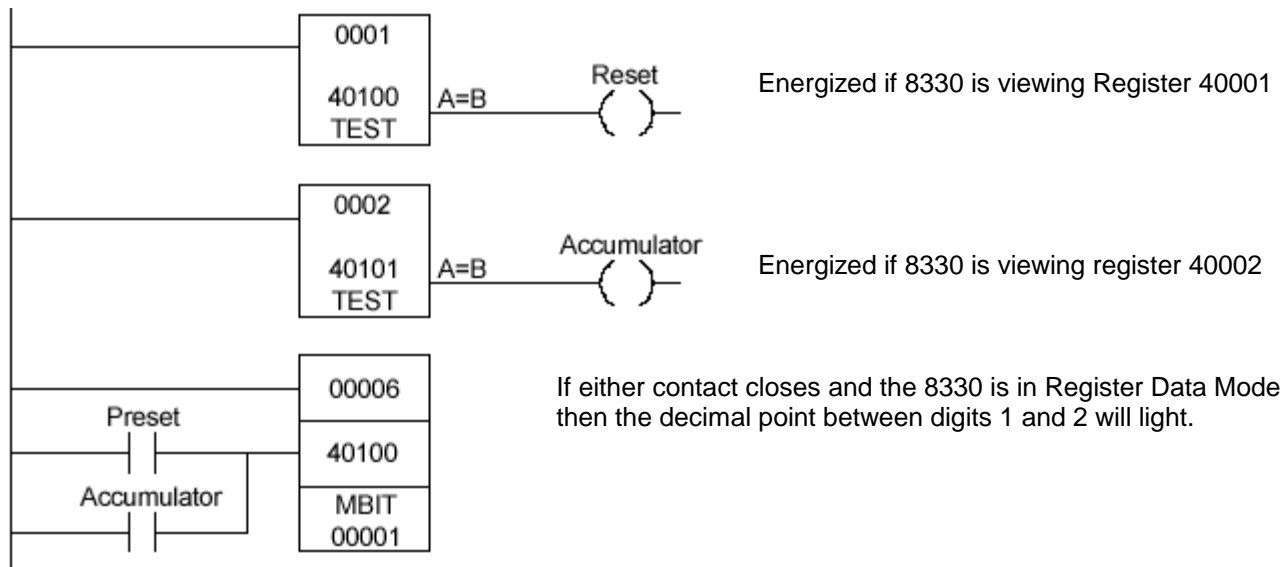

Forced Register Display

This feature allows the 8330 to be forced to a particular word address under PLC program control. The desired word address must first be put into the Last Register Entered location of the RBB (X+1). Next bit 9 in the Command Register (X) must be set to a one. The desired word address may be any location 40000 series registers. If dip switch B1 is OFF (absolute addressing), the 8330 will display the selected address number for approximately one second then display its content. If dip switch B1 in ON (offset addressing), the appropriate offset address will be calculated and displayed. If the address is below the Low Read Limit, a zero will be displayed.

If bit 9 is held ON, the NEW REG key will be kept inactive preventing the operator from selecting another register. Also writing will be allowed with a data range of 0-65535. If bit 9 is cleared to zero, the operator may select another register. Also writing will only be permitted if the address falls within the Write Limits and then only as permitted by the Write Data Limits.

Five Digit Forced Entry

If switch A5 is OFF and bit two in the Command Register is energized the 8330 will allow five digit entry. The number of digits displayed is dependant on the default setting of the PLC.

Display Segment Control

One of the enhanced mode functions allows the PLC the ability to directly control each segment of the display. Five registers in the Reserved Register Block are assigned to Display Segment Control. When bit 13 in the Command Register is set, the 8330 will continuously transfer the contents of the five assigned registers directly to the display. The 8330 will also lock preventing key entry during this time. Eight bits in each register correspond to the eight display segments. A separate register is associated with each digit. The diagram below indicates the register bit, digit segment relationship. setting a bit on will cause the segment to light. By using table-to-register functions in the PLC program it is possible to scroll data across the 8330 display. When bit 13 in the Command Register is reset the 8330 will return to its exact condition before receiving the display segment control command.

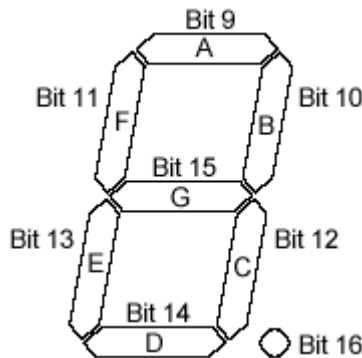

Example: Display the word HELLO. Assume the Command Register is at 40100

Register Address	8	7	6	5	4	3	2	1	Decimal Value	Digit Position	Character
40113	0	1	1	1	1	0	1	0	122	5	H
40112	1	0	1	0	1	1	1	0	174	4	E
40111	0	0	1	0	1	1	0	0	44	3	L
40110	0	0	1	0	1	1	0	0	44	2	L
40109	1	1	1	1	1	1	0	0	252	1	O
	128	64	32	16	8	4	2	1			
	Binary Weight										

PLC Initiated Error Display

When the 8330 is operated in the enhanced mode, three bits in the Command Register allow the processor the ability to force one of three error numbers on the display. The error display takes the form ERR1, ERR2, or ERR3 dependant on the Command Register bit set. The error display will remain on the 8330 until the CLR key is pushed. After the CLR key is pressed, the 8330 will reset the respective error bit in the Command Register then go to the register number ready mode. If more then one error bit is set simultaneously, the 8330 will display first the error with the highest bit number.

In the following example the Command Register is at 40100.

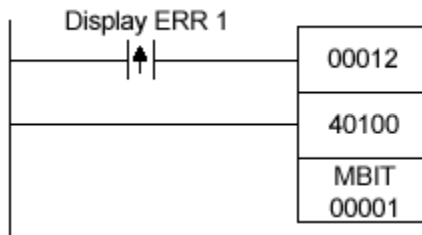

When the contact closes the 8330 will display: **ERR 1**

Offset Addressing

Up to this point all register numbers have been referred to as Absolute Addresses. For example; if you enter 40 and press NEW REG, the 8330 will read the contents of register number 40040.

A second method of accessing registers is available in the 8330 and is referred to as Offset Addressing and is enabled by setting dip switch B1 ON.

Dip switch B1 - ON Offset Addressing
 OFF Absolute Addressing

In offset addressing register numbers are decimal numbers beginning with the number one (1). Register one is always equal to the Low Read Limit currently stored in the 8330.

Example: If the Low Read Limit stored in the 8330 is register number 40, then entering 1 and pressing the NEW REG key will display the contents of register number 40040. The pattern is as follows:

Decimal Register Number	Absolute Register Address
1	40040 (Low Read Limit)
2	40041
3	40042
4	40043
5	40044

Switch	Function
A1	Assigned Write Limits, enable/disable
A2	Assigned Read Limits, enable/disable
A3	Assigned Write Data Value Limits, enable/disable
A4	Combination Lock Enabled
A5	On = 5 digit entry & display, Off = 4 digit entry & display
A6	On = Auto increment register number, Off = Reduced keystroke mode
A7	Not assigned
A8	Not assigned
B1	On = Offset Addressing, Off = Absolute Addressing

Station Address

B2	Binary Weight 8
B3	Binary Weight 4
B4	Binary Weight 2
B5	Binary Weight 1

Reserved Register Block

B6	Binary Weight 1024
B7	Binary Weight 512
B8	Binary Weight 256
C1	Binary Weight 128
C2	Binary Weight 64
C3	Binary Weight 32
C4	Binary Weight 16
C5	Binary Weight 8
C6	Binary Weight 4
C7	Binary Weight 2
C8	Binary Weight 1

Rear View of 8330GMX

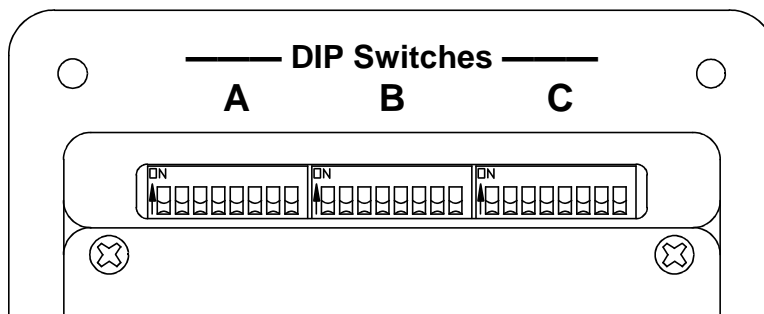

Appendix B: Operating Fault Indicators

On initial Power Up and during normal operation diagnostics are executed at key points. If an error occurs, the 8330 will display an error code indicating the type of failure or error. These include hardware failures, communication errors, Reserved Register Block set up errors and operator entry errors.

Code	Description	Possible cause and/or solution
-E1-	RAM memory failure	Re-power unit. If fault continues contact Quartech for replacement or repair authorization
-E2-	ROM checksum error	
-E3-	Base Register too high	RRB is too close to end of register memory
-E5-	No PLC response	PLC does not respond to 8330 request. May be hardware failure in PLC or 8330, incorrect cable, or broken wire.
-E6-	PLC not supported	PLC model not supported by 8330
-E7-	Illegal response received	PLC responded to 8330 request with NAK.
-E9-	Cable Disconnected	Cable is not connected at 8330 end or incorrect cable is used
-EA-	Cable Disconnected	Cable is not connected at PLC end or PLC has lost power
-Eb-	Illegal Forced Register	Register is outside the allowed limits.
-HI-	Entry above limit	Operator has attempted to enter a data value or register number that is outside the assigned limits
-LO-	Entry below limit	

Error codes will remain on the display until the CLR key is pressed. If the code is -E1- through -Eb--, pressing the CLR key will cause the 8330 to restart as though power were just applied. If -HI- or -LO- are displayed pressing the CLR key will clear the display except for a cursor allowing for a new entry.

Appendix C: Communication Cables

The following schematics and mechanical drawings describe the cables required to connect the Model 8330GMX to various Programmable Controllers.

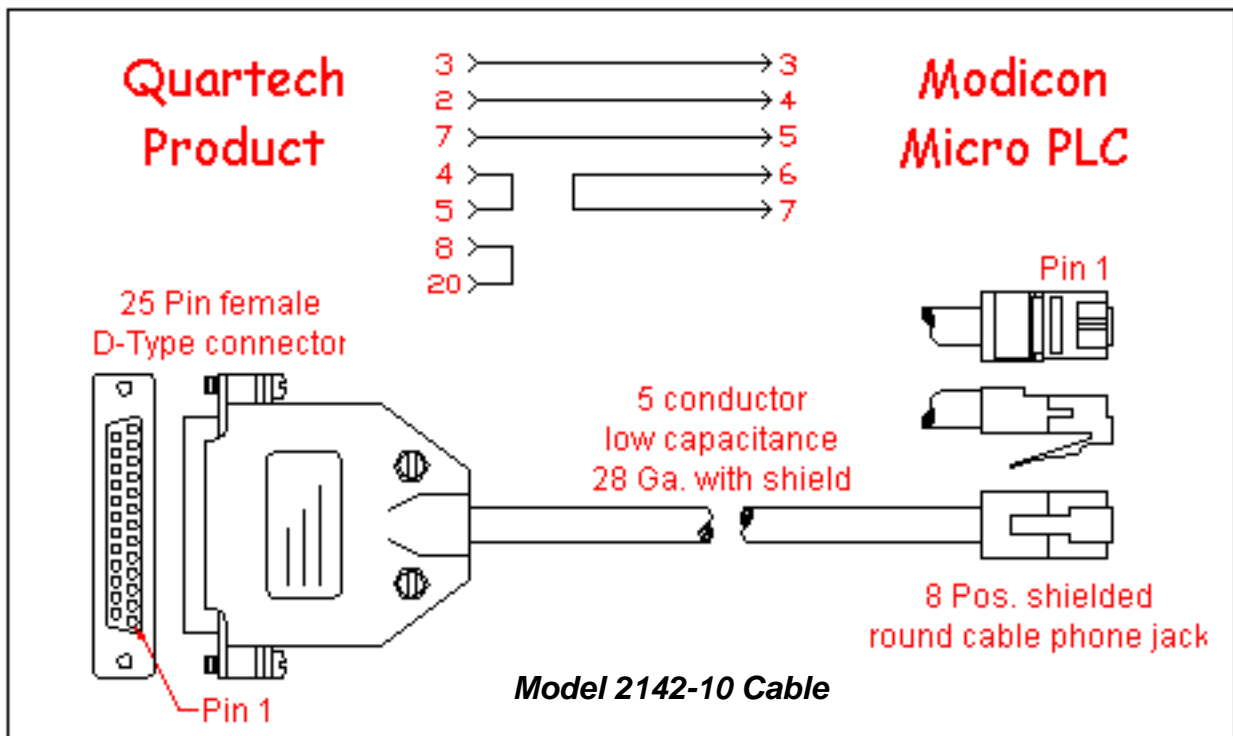
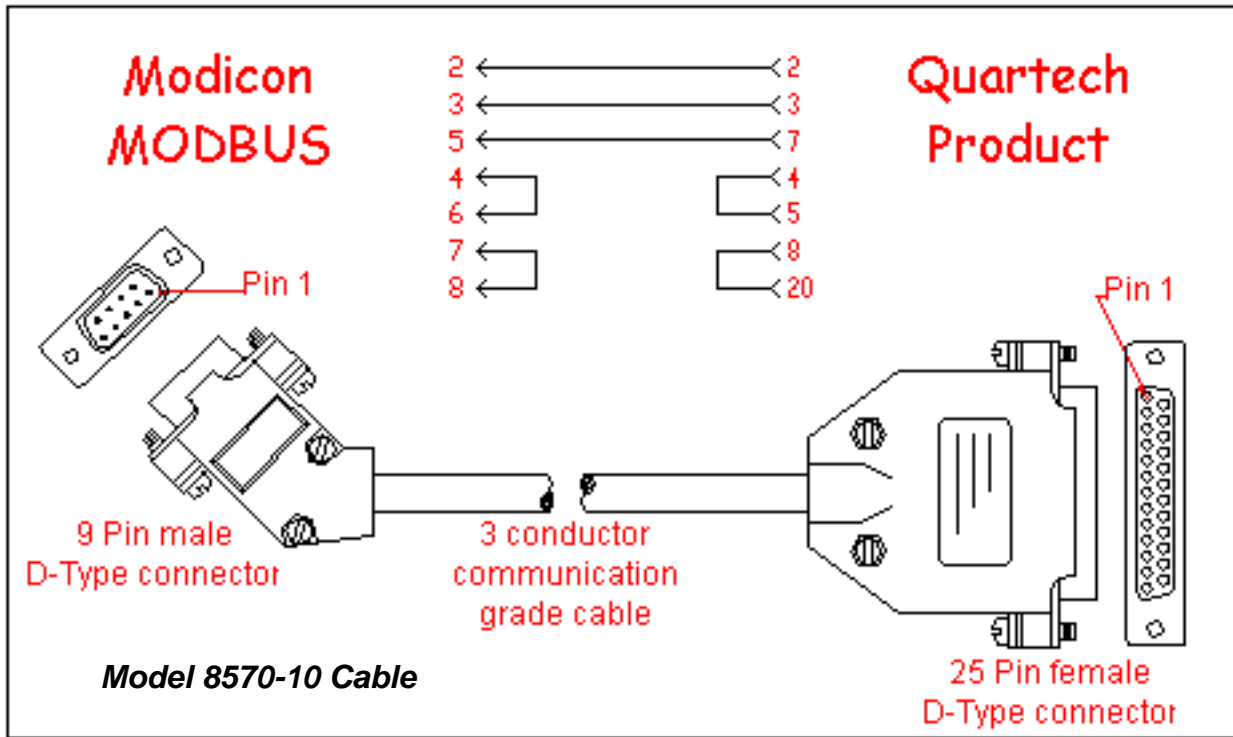

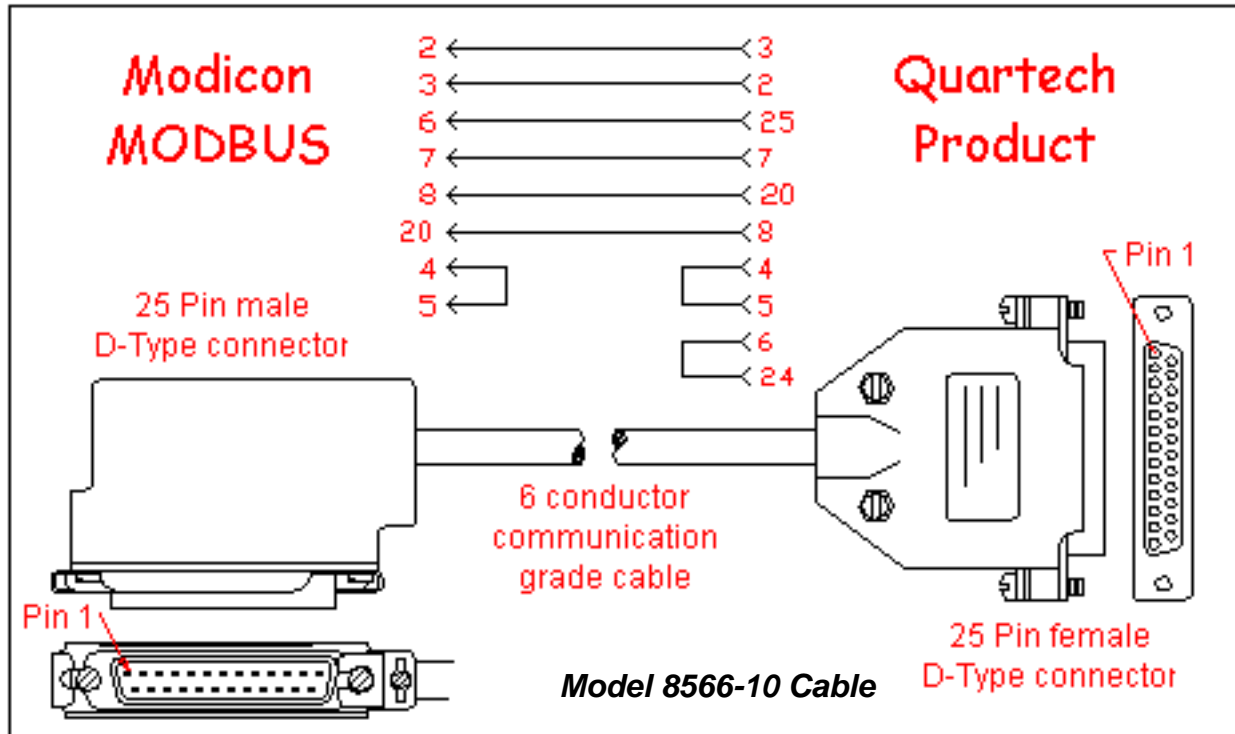

Appendix D: Specifications

- Display: 5 character seven segment LED Display,
 - . Red color, 0.57 inch character height
- Keypad: 16 tactile feedback keys rated for one million operations.
- Source Power 5.0 VDC -0/+5%, 50mv max ripple, 500ma (Model 8552)
- Communications Differential Driver, Opto-coupled input
- Temperature: 0°c to +60°c Operational, -20°c to +70°c Storage
- Humidity 10% to 95% (non-condensing), Operational or storage
- Vibration/Shock: 0.5mm displacement (X,Y,Z axis), 10-55Hz, 40G shock
- Weight: 3 pounds
- Mounting: Maintains NEMA 4 and NEMA 12 enclosure rating.

The 8330 is designed to be mounted in the door of an enclosure or on an operators console for ease of use. A template is provided to assist in the drilling and cutting of the mounting holes for the unit. Care should be taken to protect the unit from metal chips and conductive particles. Failure to protect the unit may cause damage when power is applied and may void warranty.

A minimum clearance of six inches should be kept between the unit and any other device that generates heat. In the event that the internal enclosure temperature periodically exceeds 55 degrees Celsius (131 degrees Fahrenheit), fans or a purge air system should be used to increase the air flow, and eliminate "Hot Spots" that occur within the panel.

Care should be taken when routing DC power supply cable and the communication cable. Follow these guidelines for a trouble free installation.

- The power supply should be mounted as close as possible to the 8330. If the 8330 is mounted a long distance from the PLC, the supply must be mounted local to the 8330 to allow short supply cables.
- Use at least 16 AWG wire for the 5 volt cable. If the cable must be longer than ten feet use 14 AWG wire. Do not make a power supply cable longer than 20 feet.
- The DC power lines and communication cable must be kept away from AC power lines. Keep both at least one foot away from 120 VAC lines, and two feet away from higher voltage lines. This especially applies to the communication cable. If the cables must cross power lines, cross them at right angles.
- Keep the cables away from sources of high energy fields such as arc welders, AC motors, motor starters, servo controllers, generators, induction heaters, and transformers.

Mounting Dimensions

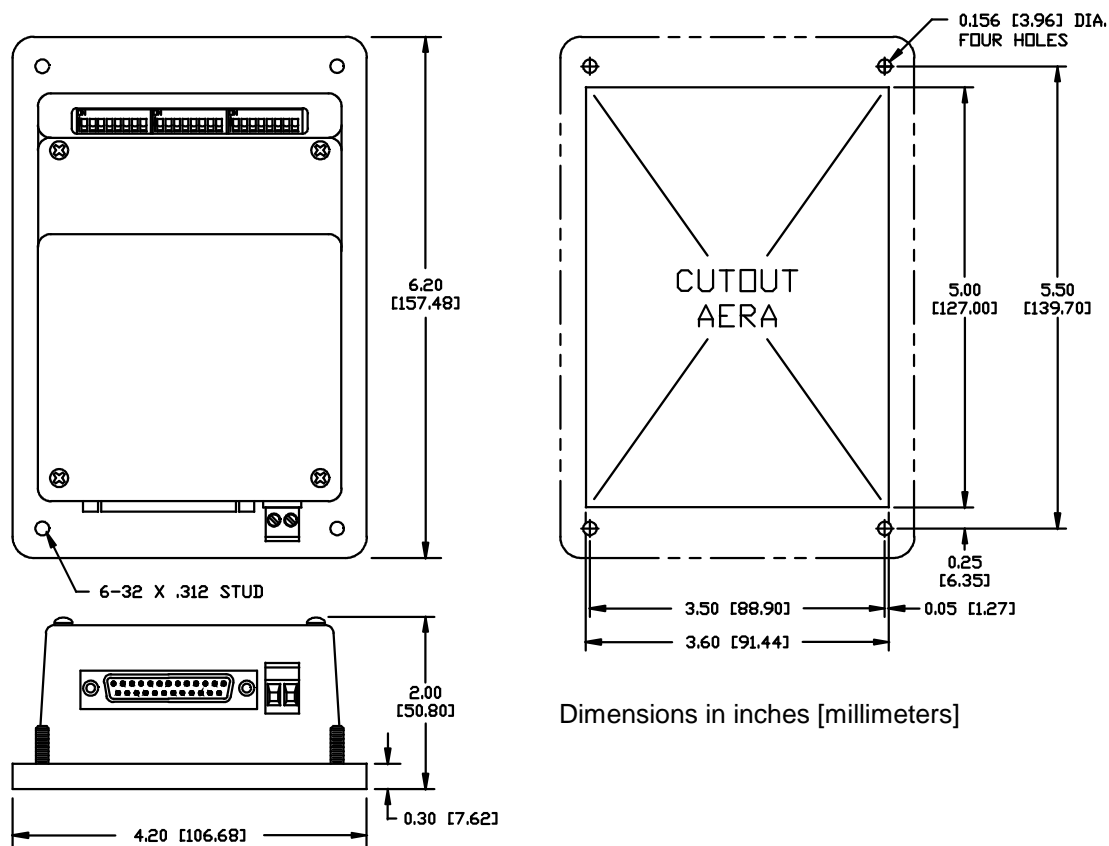

Appendix F: Reserved Register Block Work Sheet

Reserved Register Block Work Sheet

X is the address set on DIP switches B6 through C8.

Offset	Address	Value	Description
X		No Entry	Command Register
X+ 1		No Entry	Last Register Entered
X+ 2			Low Data Limit
X+ 3			High Write Limit
X+ 4			Low Write Limit
X+ 5			High Read Limit
X+ 6			Low Read Limit
X+ 7			High Data Limit
X+ 8			Combination Lock Value
X+ 9			Display segment control, position five
X+ 10			Display segment control, position four
X+ 11			Display segment control, position three
X+ 12			Display segment control, position two
X+ 13			Display segment control, position one