

Product Manual

9610

Pushbutton Station with Discrete Inputs and Outputs

Quartech Corporation

15923 Angelo Drive
Macomb Township, Michigan 48042-4050

Phone: (586) 781-0373 FAX: (586) 781-0373
www.QuartechCorp.com

PM9610 Revision 0

The product described in this document can have a variety of uses, the user and those responsible for applying this equipment must satisfy themselves as to the acceptability of each application and the use of the unit. Under no circumstances will QUARTECH CORPORATION be responsible or liable for any damage, including indirect or consequential losses resulting from the use, misuse, or application of the unit.

The text, illustrations, charts, and examples included in this document are intended solely to help explain applications of the product. Due to the many variables associated with specific uses or applications, QUARTECH CORPORATION cannot assume responsibility or liability for actual use based upon the data provided in this document.

No patent liability is assumed by QUARTECH CORPORATION with respect to the use of circuits, information, equipment, or software described in this document.

This document is subject to change without notice.

Introduction

The 9610 is a discrete input/output push button panel that features sixteen switches and sixteen tricolor light emitting diodes.

Each of the sixteen membrane switches control a reed relay and can be independently configured as a momentary push-button, a push-on push-off selector switch, or a push to latch switch.

Sixteen tricolor Light Emitting Diodes (LED) can be independently configured to follow the state of the associated optical coupler input or relay output. The on and off color is specified for each LED.

The entire configuration for 9610 is accomplished through the keypad by enabling setup utilities via DIP switches accessed through the rear cover.

24 volt DC operation....
Optical coupler inputs and relay outputs

Small size approximately 4" wide x 6" high x 2" deep

All connections via removable terminals

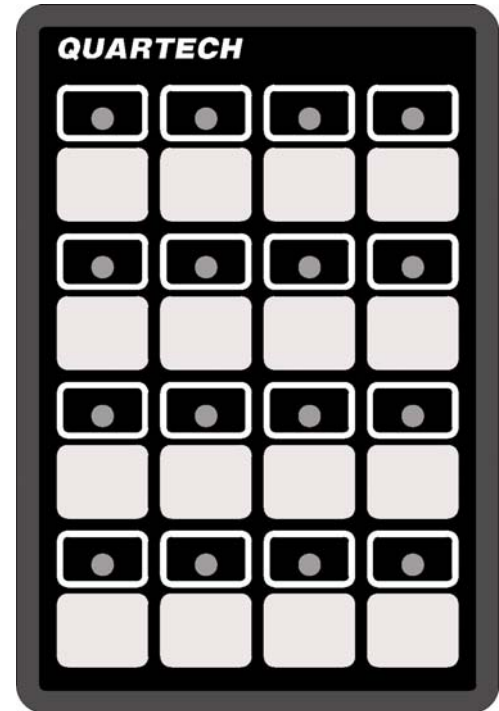

LegendMaker Utility

Create slip in switch labels with text or graphics that customize the 9610 to suit your specific application.

The LegendMaker utility is used to create switch labels, printed using your ink jet or laser printer, that can be inserted into the switch pockets of the 9610.

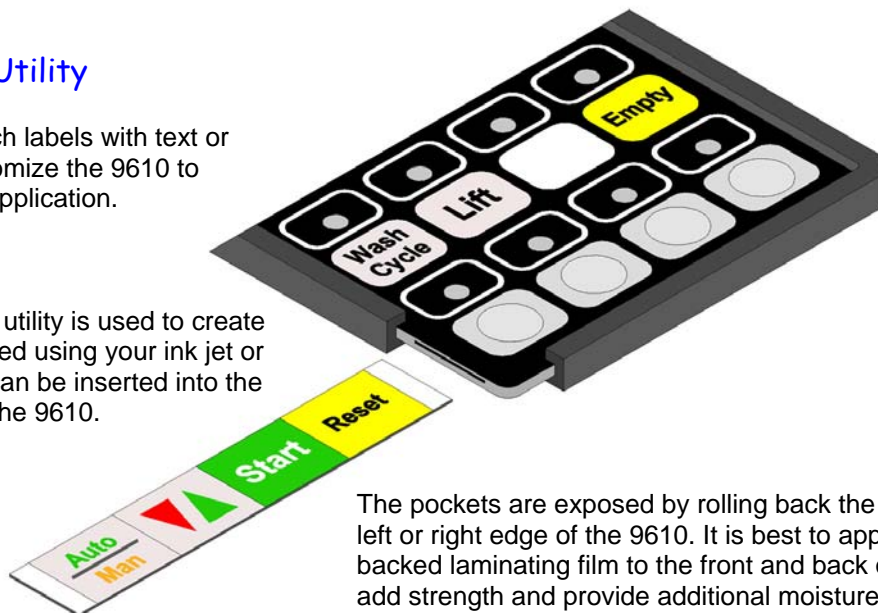

The pockets are exposed by rolling back the rubber gasket at the left or right edge of the 9610. It is best to apply an adhesive backed laminating film to the front and back of the label. This will add strength and provide additional moisture protection.

LegendMaker software is available free at QuartechCorp.com

The 9610 gasket provides NEMA 12 protection. In high humidity conditions it may be desirable to seal the gasket to the keypad. Use either a black RTV sealant for a non-permanent seal or LOCTITE 403 gel adhesive for a permanent seal.

Product Configuration

All operational configuration to the 9610 is accomplished through the keypad using three setup utilities enabled via DIP switches. The DIP switches are accessed through a cutout on the side of the rear cover.

To enter a setup mode you must remove power to the 9610, turn the appropriate DIP switch on, then reapply power.

Configuration information is stored in EEPROM memory allowing it to be changed when your application changes.

Dip switches one and two allow you to configure the LEDs. These setup utilities also allow you to configure an input so that a state change will unlatch an output relay. More information will be presented on this subject later.

An individual LED can be configured to follow the state of its associated input number, associated output number, or disabled. A LED is considered disabled when it is not assigned to an input or output. The LED will never light. When a LED is enabled you need to specify the color displayed for the off state and on state of the controlling input or output. You can also specify if the LED will light steady or flash.

DIP switch 3 allows you to configure the switches. An individual switch can be configured to function as a momentary push button, a push-on / push-off selector switch, or a push to latch switch.

Momentary Push Button: Pressing the switch will cause the associated relay output to close. It will remain closed until the switch is released.

Push-On/Push-Off Selector: Pressing the switch will cause the associated relay to change state. The relay is unaffected when the switch is released.

Push to Latch: Pressing the switch will cause the associated relay to close. The relay is unaffected when the switch is released. If the associated input has not been configured to unlatch the relay then it will remain closed until power is removed from the 9610. The associated input can be configured to unlatch the output when it changes state, Off-to-On or On-to-Off. While the relay is open the state changes on the associated input are ignored.

Dip switch four is used to enter factory utilities. If the unit is powered up with this DIP switch on the first row of LEDs will toggle between red and green. Pressing switch one will place the 9610 into a keypad test mode. When a switch is pressed the associated LED will light red. Output relays will remain off while this test is active. If instead switch two is pressed the 9610 will enter a LED test. The LEDs will cycle through the three possible colors. Other switches are assigned to functions used during factory manufacturing and testing. Pressing any switches other than one or two may put the 9610 into a function that will erase any configuration data you have saved.

DIP Switch 1 - Configure LEDs 1 through 8

One of the upper eight LEDs will light to indicate which LED the configuration shown on the lower eight LEDs applies to. If the LED is green then the configuration matches that currently held in EEPROM. If the LED is amber then the configuration shown is different than that in the EEPROM.

When power is applied the configuration for LED 1 will be pulled from EEPROM and shown on the lower eight LEDs. LED 1 will be green. Pressing a switch below any of the other upper eight LEDs will cause the associated LED to light green and its configuration to be shown on the lower eight LEDs.

Pressing any of the lower eight switches will change the configuration for the upper LED selected. Changing the configuration will cause the upper LED to change from green to amber. Once you have configured the LED press the switch below the upper LED to save the changes to EEPROM. The LED will change from amber back to green after about three seconds indicating the change was made.

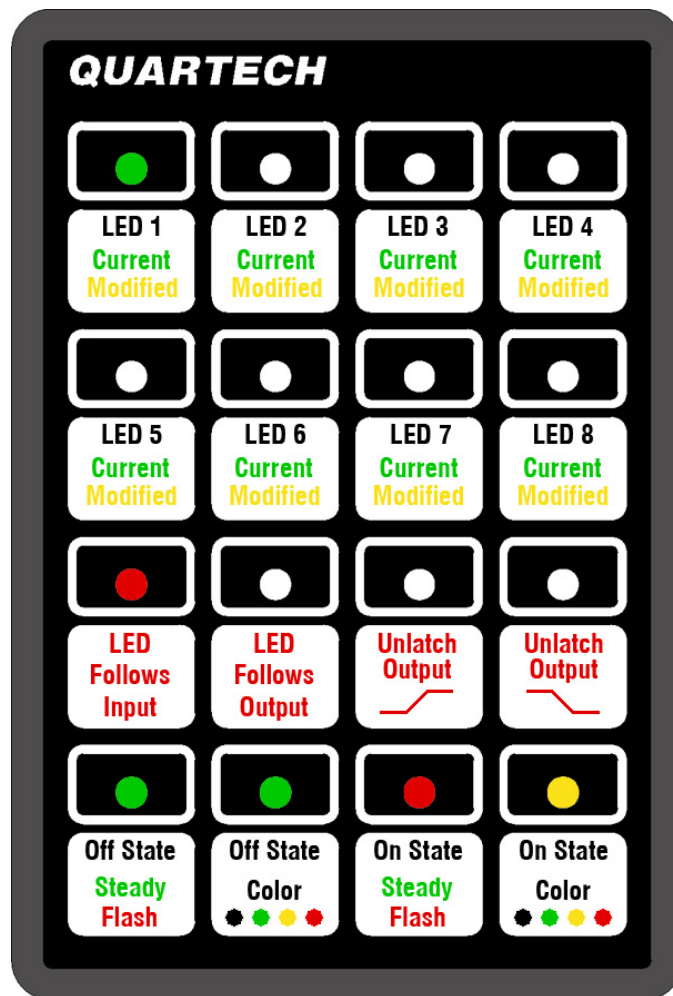

The image above shows that LED 1 is configured to follow the state of the input. When the input is off the LED will be steady green. When the input is on the LED will flash amber.

DIP Switch 2 - Configure LEDs 9 through 16

One of the lower eight LEDs will light to indicate which LED the configuration shown on the upper eight LEDs applies to. If the LED is green then the configuration matches that currently held in EEPROM. If the LED is amber then the configuration shown is different than that in the EEPROM.

When power is applied the configuration for LED 9 will be pulled from EEPROM and shown on the upper eight LEDs. LED 9 will be green. Pressing a switch below any of the other lower eight LEDs will cause the associated LED to light green and its configuration to be shown on the upper eight LEDs.

Pressing any of the upper eight switches will change the configuration for the lower LED selected. Changing the configuration will cause the lower LED to change from green to amber. Once you have configured the LED press the switch below the lower LED to save the changes to EEPROM. The LED will change from amber back to green after about three seconds indicating the change was made.

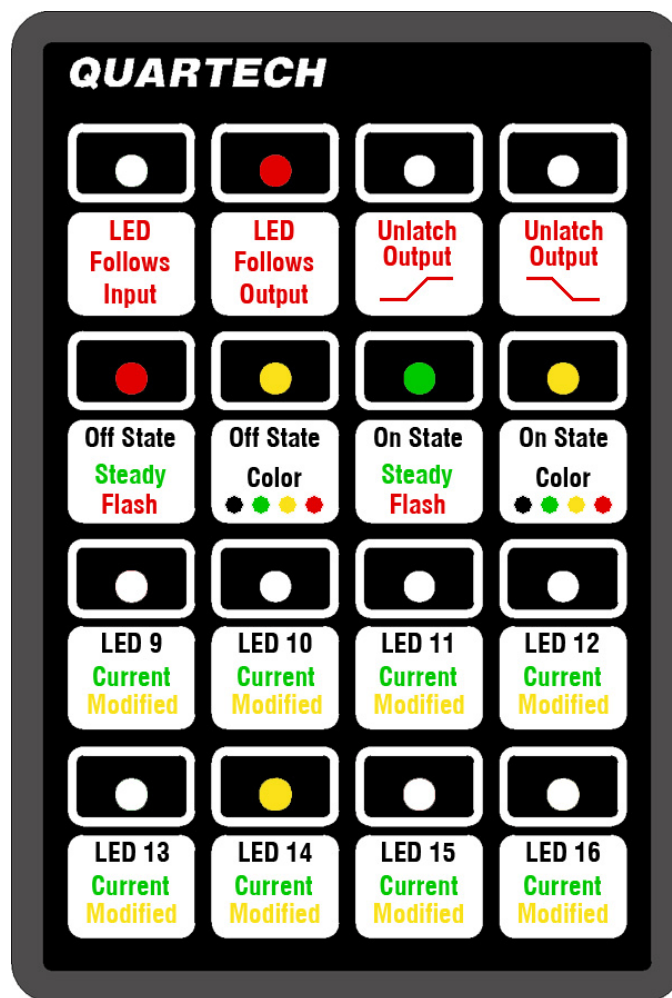

The image above shows that LED 14 has been configured to follow the state of the output. When the output is off the LED will be flash amber. When the output is on the LED will light steady amber.

DIP Switch 3 - Configure Switches

When the 9610 is powered up with DIP switch 3 on it will read the switch configuration from the EEPROM and adjust the individual LEDs to indicate the saved configuration.

Pressing a switch will cause the associated LED to change color indicating the desired switch option.

LED Off: Switch is disabled. The associated relay will always be open.

LED Green: Switch functions as a momentary push button. Pressing the switch will cause the associated relay output to close. It will remain closed until the switch is released.

LED Red: Switch functions as a push-on/push-off selector. Pressing the switch will cause the associated relay to change state. The relay is unaffected when the switch is released.

LED Amber: Switch functions as a latching button. Pressing the switch will cause the associated relay to close. The relay is unaffected when the switch is released. If the input with the same number has not been configured to unlatch the relay then it will remain closed until power is removed from the 9610. The input with the same number can be configured to unlatch the output when it changes state, Off-to-On or On-to-Off.

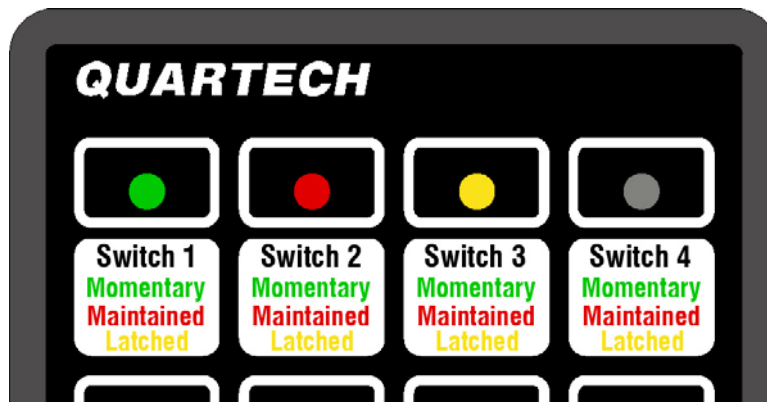

The image above shows that Switch 1 will be momentary, Switch 2 will be momentary (push-on/push-off), Switch 3 will be latching, and Switch 4 will be disabled.

Once all switches are configured to suit your application you must turn DIP Switch 3 OFF prior to removing power to save the configuration in EEPROM.

**The EEPROM write process will take about ten seconds.
When the write is complete LEDs 13 through 16 will flash green.**

It is then safe to remove power to the unit.

Error Codes

If an error is encountered the 9610 will cease normal operation and enter an error display mode. The error display mode is indicated by cycling the first two LED rows through green, amber, and red. The bottom two LED rows will indicate the error code by lighting LEDs red in a BCD format. LED row three is the most significant BCD digit. LED row four is the least significant BCD digit.

Error Code	Description
11	ROM checksum error (firmware memory)
12	RAM read/write failure
21	Multiple DIP switches set on
22	EEPROM checksum error (configuration memory)
31	DIP Switch 1 - configuration failsafe error
32	DIP Switch 2 - configuration failsafe error

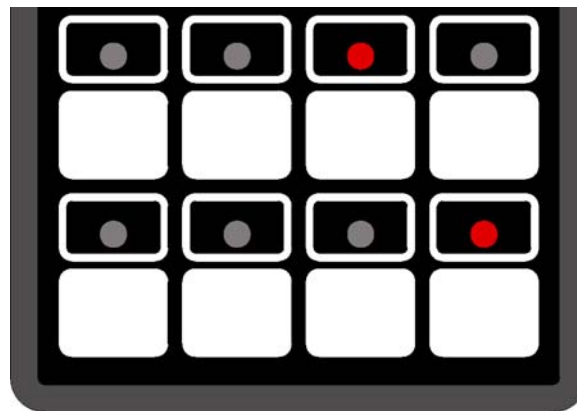

The image above shows error 21 displayed. LED rows one and two will be cycling green, amber, and red.

Since all errors are related to power-up initialization or setup it can be expected that all relay outputs will be in the open state.

Electrical Connections

The electrical schematic below shows the input/output circuitry for inputs 1 through 8 and outputs 1 through 8. Note that the group of eight inputs share a common terminal and the group of eight outputs share a common terminal. Inputs 9 through 16 and outputs 9 through 16 are configured in an identical manner with their own common terminals.

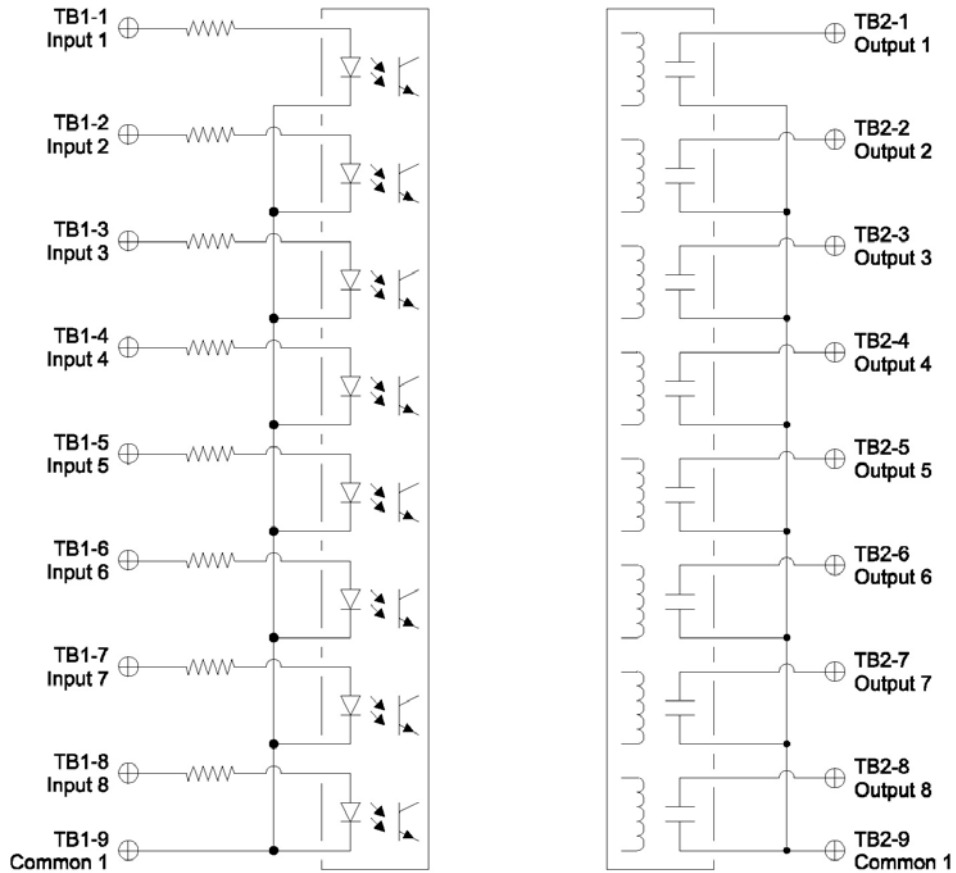

Specifications

Source Power:	24 VDC, $\pm 5\%$, @ 200 ma
Input Circuit	24 VDC, Nominal five thousand ohms
Output Circuit Current	300 milliamps @ 24VDC
Temperature:	0°C to +60°C Operational, -20°C to +70°C Storage
Humidity	10% to 95%, Non-condensing, Operational or storage
Vibration/Shock:	0.5mm displacement (X,Y,Z axis), 10-55Hz, 30G shock
Weight:	1.5 pounds

The 9610 is designed to be mounted in the door of an enclosure or on an operators console for ease of use. Enclosure cutout dimensions are shown on the next page. A cutout template is available at QuartechCorp.com.

The 9610 is 4.20 inches wide, 6.20 inches high, 2.00 inches deep

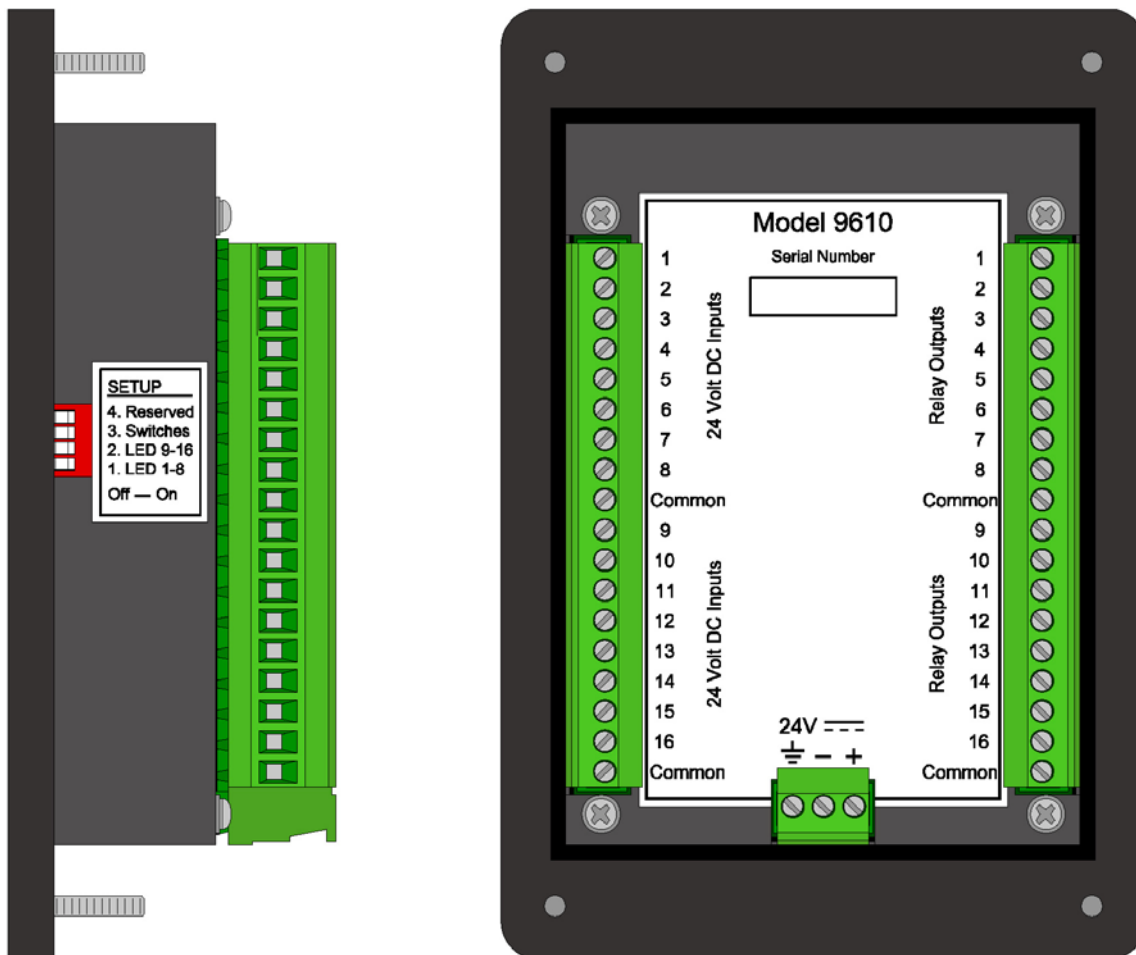

Enclosure Door Cutout Dimensions

